

E/One T260

Duplex Alternating Alarm Panel

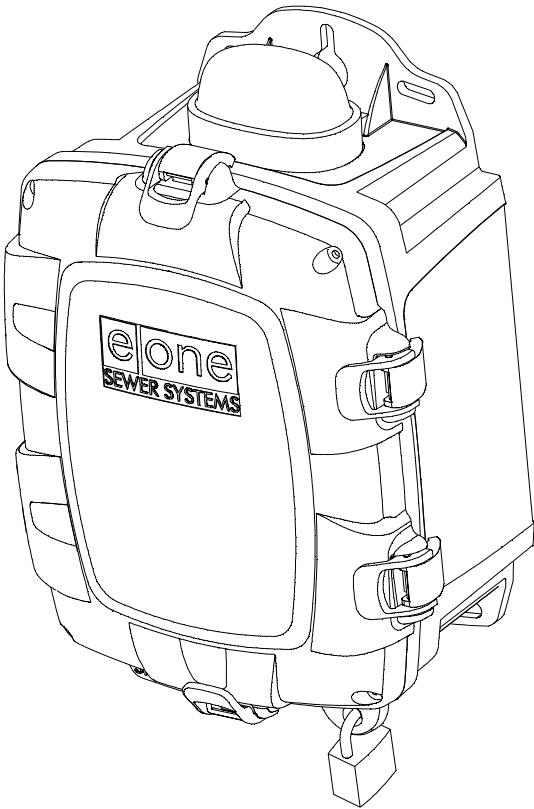

Description

The T260 Duplex Alternating Alarm panel is custom designed for use with Environment One duplex grinder pump stations.

Duplex grinder pump stations, a station with two grinder pumps, require the pumping load to be shared equally between the two pumps. Under normal conditions, one pump removes the accumulated sewage from the grinder pump basin. After 24 hours, the T260 Alternating Panel toggles the electrical supply power to the pump that was idle. If the sewage level reaches the alarm level, the two grinder pumps will operate simultaneously for 3 to 4 minutes.

If, after that time, the sewage is not below the alarm level, the alarm circuit is engaged.

The T260 Alternating Panel is supplied with audible and visual high water level alarms. The panel is easily installed in accordance with relevant national and local codes.

The T260 Panel is listed by Underwriters Laboratories, CSA, CE and NSF to ensure high quality and safety.

Standard Features

- UL-approved, corrosion-proof enclosure
- NEMA 4X-rated enclosure with hinged access panel
- Lockable latch with keyed-alike padlock included
- Circuit breakers
- Terminal blocks & ground lugs
- Dry contacts
- Lead/lag, run and alarm indicator lights
- Manual push-to-run

Optional Features

- Hour meters
- Generator receptacle with auto transfer

DUPLEX ALTERNATING PANEL T-260

EXTERNAL VISUAL & AUDIBLE ALARM
EXTERNAL LATCHING MANUAL SILENCE
MANUAL RUN
PUMP RUN INDICATORS
CONFORMAL COATED CIRCUIT BOARD
PADLOCK
ALARM DRY CONTACT
NEMA 4X ENCLOSURE ASSEMBLY

CORROSION PROOF THERMOPLASTIC
POLYESTER APPROVED BY UL FOR
ELECTRICAL CONTROL ENCLOSURE

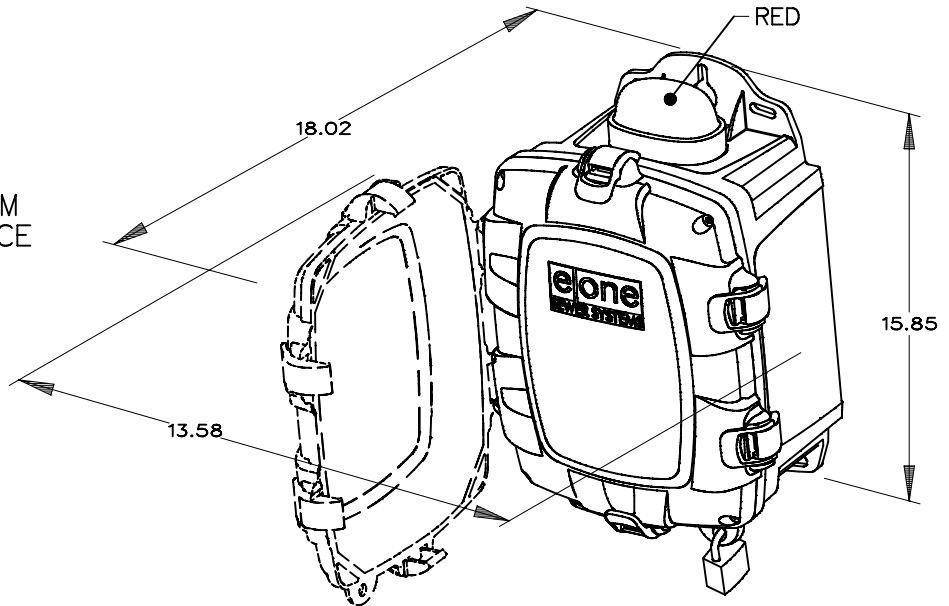

OPTIONS:

HOUR
METER

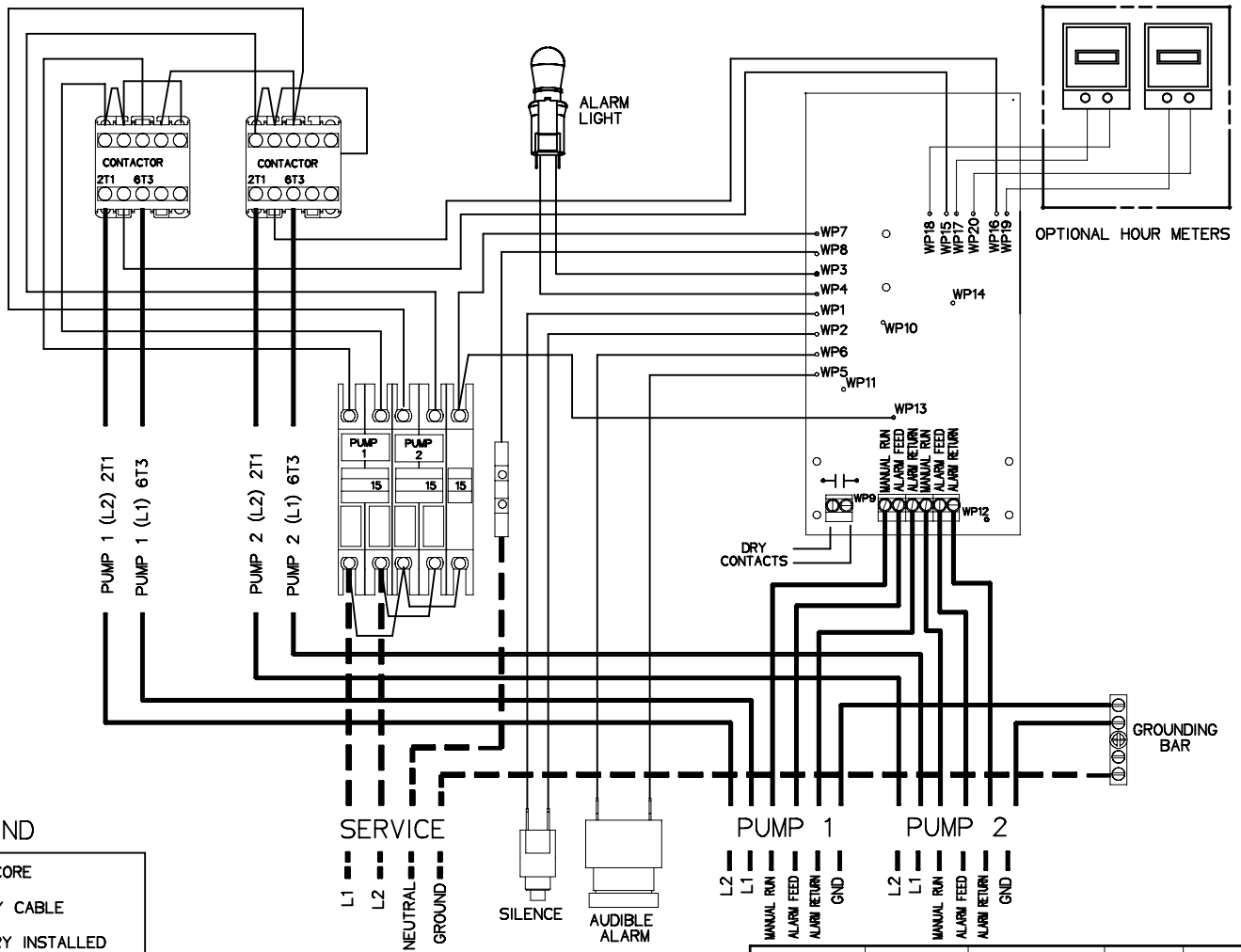

LEGEND

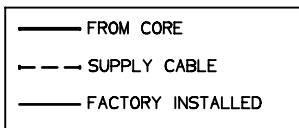

PIN	FUNCTION	2000S	EXTREME
1	MANUAL RUN	RED	BROWN
2	L1	BLACK	RED
3	L2	WHITE	BLACK
4	GND	GREEN	GRN/YEL
5	ALARM FEED	ORANGE	YELLOW
6	ALARM RETURN	BLUE	BLUE

CONTROL CABLE:

TYPE TC: DIRECT BURIAL, 12AWG,
SIX CONDUCTOR



AD	SM	09-24-07	C	N/A
DR BY	CHK'D	DATE	ISSUE	SCALE



DUPLEX T-260 ALTERNATING PANEL,
240V 60Hz DOUBLE POLE POWER
WIRED LEVEL CONTROL

LM000329 P1