

SENTRY Protect Plus SIMPLEX PANEL Installation and Operation Manual

**Environment One Corporation
240 VAC Two Leg Power**



Setup & Operation Index

Setup & Operation Index	2
Sentry Protect Plus Menu Flowchart	3
Overview	4
Wiring Instructions	5
System Initialization	5
DIP Switch	5
Cold Start the Panel.....	5
Programming Setup.....	6
Run Limits.....	6
Alarm Delay	6
Power Delay	7
Normal Operation.....	7
Manually Running Pump	8
High Level Alarm	8
Trouble Alarm.....	8
Run Dry, Overpressure, and Brownout Operation.....	8
Pump Performance	9
Clearing Statistics	10
Initialization	10
Cold Start	10
Calibration.....	11
Clear Trouble	11
Diagnostics.....	11
Trouble Shooting.....	11
Testing Instructions and Charts.....	11
Troubleshooting Chart	11
Continuity Test.....	11
Amperage Test	12
Typical Pump Wiring Diagram – 240V 2-Leg (Extreme Hardwired)	13
Typical Pump Wiring Diagram – 240V 2-Leg (Extreme Wireless)	14
Trouble Shooting Panel Symptoms and Tests	14
Technical Q&A (See Q&A document for complete list).....	15
Appendix	17
Typical Panel Wiring Diagram – 240V 2-Leg.....	17

Sentry Protect Plus Menu Flowchart

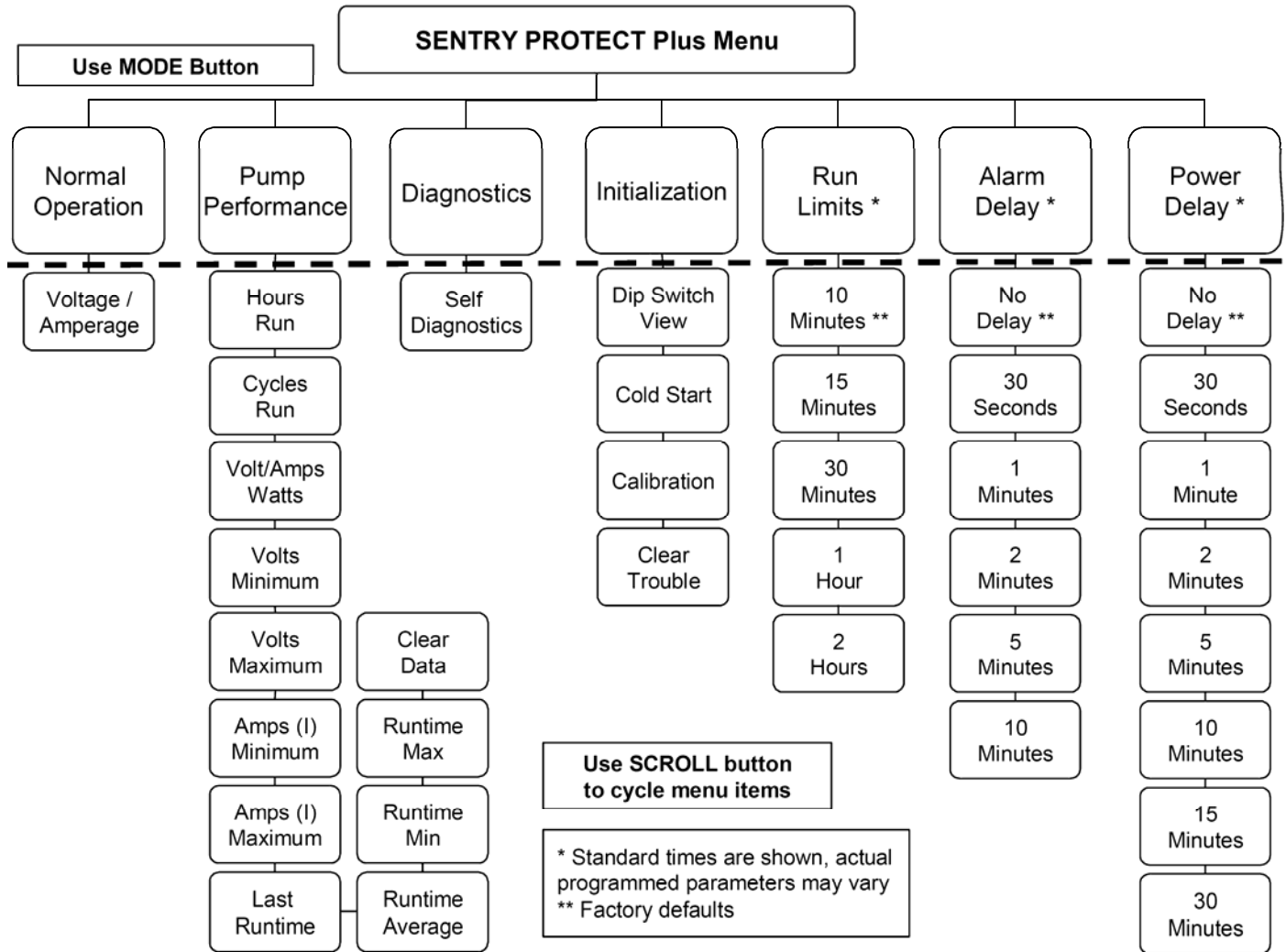

Overview

The Sentry Protect Plus panel is an Environment One full-featured Alarm/Monitor panel. The Sentry Protect Plus panel monitors the following operations:

- Pump Run Dry Condition (Pump running out of water)
- Pump Overpressure Condition (Pump operating at abnormally high power level)
- Brownout Condition (Mains voltage under 12% of nameplate rating)
- High Liquid Level
- High & Low Amperage drawn by the Pump
- High & Low Voltage to the Pump
- Extended Runtime by the Pump (field adjustable)

The following information on the pump operation can be viewed from the Sentry Protect Plus Panel:

- Realtime pump voltage and current
- Realtime power to pump
- Cycles & Hours (can be reset)
- Minimum & Maximum Amperage (can be reset)
- Minimum & Maximum Voltage (can be reset)
- Minimum, Maximum, Average, and Last Run Cycle (in Minutes, can be reset)
- Trapped error conditions

The following operations are field adjustable:

- Extended Run Alarm Time (factory set at 10 minutes)
- Alarm Delay (factory set to "NO DELAY")
- Power Delay (factory set to "NO DELAY")

The following are the hardware features:

- IP65 Rating
- Enclosure made from Thermoplastic Polyester
- Separate Circuit Breakers for Alarm and Pump
- Audible & Visual Alarm indicators
- Silence for Audible Alarm
- Alarm Dry Contacts that operate with or without power to the panel (for DC power driven alarm devices only). Intended for use with Environment One Remote Sentry, sold separately.
- Dry and Powered Alarm Contacts (will only operate when the power is on to the alarm board)
- Alarm Delay up to 10 minutes
- LCD Display to show Pump & Panel operating conditions
- Four Status Indicators
 - Ready
 - Pump Running
 - Trouble
 - High Level Alarm
- Eight Selectable Modes to view or change panel operation
- Low Voltage Protection
- Manual Pump Run Button

- Startup Delay after Power Outage

The Sentry Protect Plus Panel is properly installed by following the steps below.

1. Mount and wire the panel per the instructions on the enclosure door.
2. “Cold Start” the panel
3. Set all limits and delays:
 - a. **RUN LIMIT** defaults to 10 minutes. If this is correct no changes are needed.
 - b. **ALARM DELAY** defaults to no delay. If this is correct no changes are needed.
 - c. **POWER DELAY** defaults to no delay. If this is correct no changes are needed.

Wiring Instructions

Due to the different optional features and voltages, the Sentry Protect Plus panel wiring can change from model to model. Wire the Sentry Protect Plus panel per the wiring decal inside the door.

The typical wiring diagrams can be found in the Appendix Section of this document.

System Initialization

A number of parameters, some of which will be unique to the installation site, must be set on-site. These include various operating delays.

DIP Switch

A three position miniature switch (DIP switch), labeled S1, programs Sentry Protect Plus for the mains voltage and other parameters to be applied. In the following voltage selection table “U” represents a switch in the Up (ON) position and “D” represents a switch in the Down (OFF) position. The DIP switch must be programmed with mains power off (Alarm Breaker off). ***It is essential that the DIP switch is properly set for the mains voltage applied.***

240 VAC, 60 Hz	UUU
240 VAC, 50 Hz	UUD
220 VAC, 50 Hz	UDU
120 VAC, 60 Hz	UDD
120 VAC, 60 Hz	DUU
220 VAC, 50 Hz	DUD
240 VAC, 50 Hz	DDU
240 VAC, 60 Hz	DDD

Cold Start the Panel

Press the **Mode** button 4 times until the LCD reads “<INITIALIZATION>” and the **Initialize System** LED is lit. After a moment the LCD will change to “DIP SWITCH>” and display the programmed DIP switch configuration. Press the **Scroll** button 1 time. The LCD will show “COLD START”. Press the **Enter** button. When the LCD prompts “ARE YOU SURE?”, press the **Enter** button again. The panel will restart.

Programming Setup

Run Limits

The Run Limit is the time the pump can continuously run before a predictive trouble alarm is announced. Note that the following values may vary.

Press the **Mode** button until the item **Run Limit** is selected. The LCD will show "<RUN LIMIT>", then after a short pause, "10 MINUTES". There are five choices for duration.

- "10 MINUTES"
- "15 MINUTES"
- "30 MINUTES"
- "1 HOUR"
- "2 HOURS"

Use the **Scroll** button to display the desired duration then press the **Enter** button to select it. The label "Mem>" will appear to the left of the selected item to indicate that the selection is set.

The factory default is "10 MINUTES".

Alarm Delay

The Alarm Delay is the amount of time between the pump triggering a high level alarm and the panel annunciating it with the buzzer and lamp. Note that the following times may vary.

Press the **Mode** button until the item **Alarm Delay** is selected. This is displayed by the LCD prompting "<ALARM DELAY>", then "NO DELAY". The Alarm Delay parameter provides a delay between the detection of a High Level Alarm condition and its annunciation. See "Normal Operation" on Page 7.

There are six delay choices:

- "NO DELAY"
- "30 SECONDS"
- "1 MINUTE"
- "2 MINUTES"
- "5 MINUTES"
- "10 MINUTES"

Use the **Scroll** button to display the desired delay then press the **Enter** button to select it. The label "Mem>" will appear to the left of the selected item to indicate that the selection is set.

The factory default is "NO DELAY".

Note: The Alarm Light, Buzzer and Both Dry Contacts will be delayed when the alarm pressure switch closes if a delay time is set. The Powered Remote Terminals will turn on as soon as the alarm pressure switch closes.

There is no delay of any function for trouble Alarms.

Power Delay

The Power Delay is the amount of time between the detection of power to the alarm board and when power is allowed to the pump. The power to the alarm board must be within acceptable limits before the delay begins. Note that the following times may vary.

Press the **Mode** button until the item **Power Delay** is selected. This is displayed by the LCD prompting "<POWER DELAY>", then "NO DELAY". The Power Delay parameter provides a delay between the detection of sufficient mains voltage/power to operate the pump and the energizing of the panel contactor which applies this power to the pump.

There are eight delay choices:

- "NO DELAY"
- "30 SECONDS"
- "1 MINUTE"
- "2 MINUTES"
- "5 MINUTES"
- "10 MINUTES"
- "15 MINUTES"
- "30 MINUTES"

Use the **Scroll** button to display the desired delay then press the **Enter** button to select it. The label "Mem>" will appear to the left of the selected item to indicate that the selection is set.

The factory default is "NO DELAY".

Normal Operation

When mains power is applied to the Sentry Protect Plus panel:

1. The system will prevent the energizing of the **optional** power contactor which prevents the mains voltage from being applied to the pump.
2. The system automatically retrieves all programmed parameters and the last operating status.
3. The LCD displays "POWER RISING" for a short period (approximately five seconds) during which time the system will confirm that the supplied voltage is within acceptable limits to permit normal pump operation.
4. If the mains voltage is adequate, then the contactor will be energized. The system will then advance into normal operation after an additional delay. This delay is set by the value selected in the **Mode** "POWER DELAY".
5. If the mains voltage is less than the minimum required for proper operation (see System Specifications in the nameplate), the LCD will display "BROWNOUT" and continue to prevent the contactor from providing power to the pump. Note that, since system error conditions are latched, if the Alarm breaker is turned on but the Pump breakers are off, the LCD will latch the prompt "BROWNOUT". This situation may arise during pump commissioning/testing when filling the tank with water. The prompt may subsequently be extinguished (once the Pump breakers are turned back on) by turning the Alarm breaker off, then on (see **Trouble Operation**, below).

Note: The Ready LED will blink when the Sentry Protect Plus is evaluating the incoming power or if the power is outside of acceptable limits.

Note that a panel detecting a high level alarm condition prior to the application of adequate mains voltage will hold off power to the pump until the programmed power delay has completed. However, the alarm delay will start immediately upon detection of the alarm and will be annunciated at the completion of the alarm delay.

Note that a preset power delay may be terminated early by pressing and holding the **Scroll** button until the LCD prompts “END POWER DELAY”. After releasing the button the contactor will be energized and power will be applied to the pump.

Note that the Ready LED will blink until power is applied to the pump, at which point it will be fully turned on.

In **Normal Operation** the system will monitor pump voltage, pump current, pump power, pump runtime, and High Water Level as well as annunciate pump status. If there are no abnormal conditions, the LCD will alternately display “XXX VAC/XX.X AAC” (which provides the real time pump voltage and current, updated every ½ second) and “SYSTEM NORMAL”.

Manually Running Pump

Press and hold the **Enter** button to manually run the pump. A delay of 2 seconds may occur before the pump runs. Release it to stop the pump. The Pump Running LED will turn on whenever the pump is running. The volts and amps are displayed on the LCD.

High Level Alarm

Should the system go into a high level alarm, it will light the red High Level Alarm LED, light the panel lamp, and turn on the buzzer. The LCD prompt “SYSTEM NORMAL” is replaced with the prompt “HIGH LEVEL ALARM”.

Trouble Alarm

The trouble alarm is activated by detection of an out-of-bounds pump voltage, pump current, pump real power draw or excessive pump runtime. The red Trouble LED is turned on, the panel lamp blinks, and the LCD replaces “SYSTEM NORMAL” with one or more trouble prompts: “VOLTAGE TROUBLE”, “CURRENT TROUBLE”, “RUN DRY”, “OVERPRESSURE”, or “RUNTIME TROUBLE”.

Run Dry, Overpressure, and Brownout Operation

The Sentry Protect Plus panel continuously monitors for Run Dry, Overpressure, and Brownout trouble conditions:

1. Brownout. Power to the pump is conveyed through a high power contactor. Should the mains voltage drop below a preset Turn-off Level – about 12% less than the nameplate rating, selected by the DIP switch, above – the contactor will open and the LCD will display “BROWNOUT”. This condition will self-clear, permitting the contactor to close, only if the mains voltage rises above a preset Turn-on Level (about 8% less than the nameplate rating, also selected by the DIP switch).
2. Run Dry. Should the panel detect a sustained, abnormally low pump power level (below a pre-determined threshold) it will open the contactor and the LCD will display “RUN DRY”. Typically, a very low power level is associated with the liquid level in the pump dropping

below the pressure bell housing. Shutting off the pump for this condition prevents possible damage to the grinding mechanism. After about a 20 minute delay the panel will close the contactor and permit the pump to run. The contactor will remain closed for no more than approximately 8 seconds should the panel continue to detect a low pump power level, at which point, it will, again, open the contactor. This run dry cycle may continue indefinitely; however, at the third run dry cycle the panel will light the alarm lamp and turn on the buzzer. The alarm condition will self-clear if, during the time that the pump is permitted to run, the wattage level returns to normal and the pump automatically shuts off. The only condition which overrides the cyclic run dry operation is the occurrence of a high level alarm. For this state the contactor is closed, the pump is forced on, the High Level Alarm LED and panel lamp will light, and the buzzer will turn on. The buzzer may be silenced at any time by pressing the Silence button.

3. Overpressure. Should the panel detect a sustained, abnormally high pump real power level (above a pre-determined threshold) it will open the contactor and the LCD will display "OVERPRESSURE". Typically, a very high power level is associated with a blocked discharge line. After about a 20 minute delay the panel will, again, close the contactor and permit the pump to run. The contactor will remain closed for no more than approximately 8 seconds should the panel continue to detect high pump wattage, at which point, it will open the contactor. This overpressure cycle may continue indefinitely; however, unlike the run dry cycle, above, the panel will not light the alarm lamp continuously and turn on the buzzer. Additionally, the occurrence of a high level alarm, while it will light the High Level Alarm LED and panel lamp and turn on the buzzer, will not close the contactor. The overpressure condition will self-clear if, during the time that the pump is permitted to run, the power level returns to normal and the pump will automatically shut off.

Note that for the Trouble operation, above, the LCD will latch the prompt associated with the last occurring trouble condition. These prompts will clear only after either the mains power turns off, then on, or else the Alarm circuit breaker is turned off, then on.

Pump Performance

The Sentry Protect Plus system accumulates statistics from twelve different parameters.

Press the **Mode** button twice to light the Pump Performance LED. Upon Selection of this item the LCD shows "<PERFORMANCE>", then "Hours>XXXXXX.X HRS".

Use the **Scroll** button to advance through the list.

The statistics collected are:

- "Hours>XXXXXX.X HRS" - the total number of running hours accumulated by the pump since the system was initialized.
- "Cycles>XXXXXX" - the total number of pump cycles accumulated since the system was initialized.
- "XXX VAC/XX.X AAC" - the pump voltage and current in real time.
- "POWER> XXXX W" – the pump power (wattage) draw.
- "Vmin> XXX VAC" - the minimum pump voltage recorded since the system was initialized.
- "Vmax> XXX VAC" - the maximum pump voltage recorded since the system was initialized.
- "Imin> XX.X AAC" - the minimum pump current recorded since the system was initialized.
- "Imax> XX.X AAC" - the maximum pump current recorded since the system was initialized.

- “Last> XX.X MIN” or “Last> XX.X HRS” - the runtime of the last pump cycle. Note that the pump cycle ends when the pump turns off. At this point the Cycles counter is incremented.
- “Ravg> XX.X MIN” or “Ravg> XX.X HRS” - the average pump runtime since the system was initialized.
- “Rmin> XX.X MIN” or “Rmin> XX.X HRS” - the minimum pump runtime since the system was initialized.
- “Rmax> XX.X MIN” or “Rmax> XX.X HRS” - the maximum pump runtime since the system was initialized.

Notes:

While the pump is running, “real time” readouts will have a blinking decimal point indicating the system is updating the readout on regular intervals. It will stop blinking when the pump turns off.

Data is stored to memory every 15 minutes. If the power to the alarm board is interrupted it is likely it will not store any of the operational information that occurred in as much as the last 15 minutes. All other data stored before the last 15 minutes will be stored and viewable when the power recovers.

“MIN” represents time in minutes.

“HRS: represents time in hours.

“AAC”: represents current in Amps, Alternating Current.

“VAC”: represents voltage in Volts, Alternating Current.

“W”: represents power in Watts.

Clearing Statistics

The item “CLEAR STATISTICS” is included in the Pump Performance menu group in order to clear all accumulated statistics.

- This item can be accessed by pressing the **Enter** button. However, a passcode will need to be entered in order to complete the clearing operation.

Initialization

Selection of this item is displayed by the LCD prompting “<INITIALIZATION>“, then “DIP SWITCH> YYY” where Y is either the letter “U” representing the Up position or “D” representing the Down position. This readout provides feedback about the setting of the DIP switch on the circuit board. This setting should only be changed by the factory unless instructed by an Environment One representative.

The other items in this group which can be displayed by pressing the **Scroll** button are “COLD START” and “CALIBRATION”:

Cold Start

Select this item by pressing the **Enter** button (bypass it by pressing the **Scroll** button). Selecting this causes all operating parameters except the voltage/current calibration values to be initialized to the factory defaults. If selected, the LCD will prompt “ARE YOU SURE”. Press the **Enter** button to accept it. The LCD will prompt “ERASING DATA” then, after a brief delay, “DATA ERASED”.

Calibration

Calibration is a factory only item that cannot be performed properly in the field. This feature is also passcode protected to prevent accidentally performing this function.

Clear Trouble

In the event a trouble condition will not automatically correct itself it, and all trouble conditions, can be cleared by selecting this item and pressing the **Enter** button.

Diagnostics

Selection of this item is displayed by the LCD prompting "<DIAGNOSTICS>", then "LEDS/RELAYS". During this last prompt, for a period of about four seconds,

1. The Ready, Pump Running, Trouble, and High Level Alarm LEDs will turn on.
2. The panel lamp, buzzer, and redundant run relays will be energized and the contactor will be de-energized.
3. At the conclusion of this period the above LEDs will turn off, the relays will be de-energized.

Trouble Shooting

Testing Instructions and Charts

Troubleshooting Chart

Condition	Possible Causes	Troubleshooting Steps
Alarm ON - Pump Running NOT Pumping	Blocked discharge line, worn stator, leak in pump discharge assembly, underground wire damage, inoperable controls	1. Verify Voltage (216V-264V) (108V-132V) 2. Wiring - see p. 4 3. Continuity Test 4. Amperage Test
Alarm ON - Pump NOT Operating	Incorrect voltage, plugged breather, low fluid level, wet or corroded controls, inoperative controls, faulty panel breaker	
Alarm Activates Frequently	High flow, plugged vent or breather, sensing line leak, line blockage or worn stator, underground wire damage	
Noisy Pump	Normal operation, low voltage, blocked discharge, damaged stator, worn motor bearing	

Continuity Test

1. Verify power is off by checking the voltage (voltmeter/multimeter).
2. Use an ohm meter (multimeter) and set to 2000K (or 2Meg) scale for continuity test.
3. Place one probe on the lead under Color 1, and the other lead on Color 2 (allow 5 sec to stabilize).
4. Verify the readings are "Normal."
5. If one is not "Normal," repeat the entire procedure in the panel with the EQD disconnected, and again on the pump EQD (see terminal connection chart).

Continuity Test (set meter to 2000k, or 2 meg scale)				
Color 1	Color 2	Operation	Normal Reading	
			in liquid	out of liquid
Red (2)	Brown (1)	On-Off Switch	0, short or closed = ON	OL, 1, open = OFF
Yellow (5)	Blue (6)	Alarm Switch	0, short or closed = ON	OL, 1, open = OFF
GRN/YEL (4)	Red (2), Brown (1), Black (3)	Short to Ground	OL, 1, open = no short	OL, 1, open = no short
GRN/YEL (4)	Blue (6)	Short to Ground	0, short = closed	0, short = closed
GRN/YEL (4)	Yellow (5)	Short to Ground	0, short = closed	OL, 1 = open
Brown (1)	Blue (6), Yellow (5), GRN/YEL (4)	Short in Push-to-run circuit	OL, 1, open = no short	OL, 1, open = no short
Brown (1)	Black (3)	contactor coil	.001 to .003	.001 to .003

Amperage Test

1. Hook an amp meter around the BLACK wire from the pump
2. Press the Push-to-run button (if necessary)
3. NOTE: Amperages may vary from this chart by as much as 1 amp.
4. Verify the zero-head amperage to calibrate.

Approximate Amp Draw Readings				
Amps @ 240V (@ 120V)	PSI	Head (ft)	GPM	Comments
4.9 or less (9.8)	0	0	0	Worn stator
5.6 (11.2)	10	24	14	Normal
5.8 (11.6)	20	46	13	Normal
6 (12)	30	70	12	Normal
6.2 (12.4)	40	92	11	Normal
6.5 (13)	50	115	10	Normal
6.8 (13.6)	60	138	9	Normal
8 and higher (16)	90+	207+	varies	Plugged Discharge line or bad bearings
over 15 (30)	0	0	0	Jammed Grinder or Shorted Motor

Typical Pump Wiring Diagram – 240V 2-Leg (Extreme Hardwired)

SUPPLY CABLE WIRE COLOR & OPERATION

EQD Pin #	Wire Color	Function
1	Brown	Manual Run
2	Red	L1
3	Black	L2 or Neutral
4	Green w/ Yellow Stripe	Ground
5	Yellow	Alarm Power Feed
6	Blue	Alarm Power Return

Supply Cable

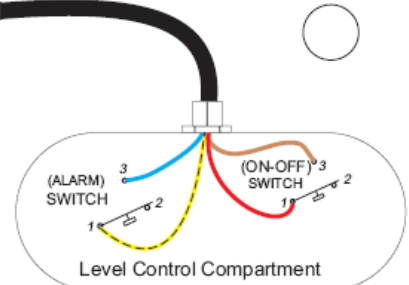

HARD WIRE OPTION

Alarm Yellow and Blue wires go to the alarm panel only Motor Control Red and Brown wires go to both alarm panel and motor contactor

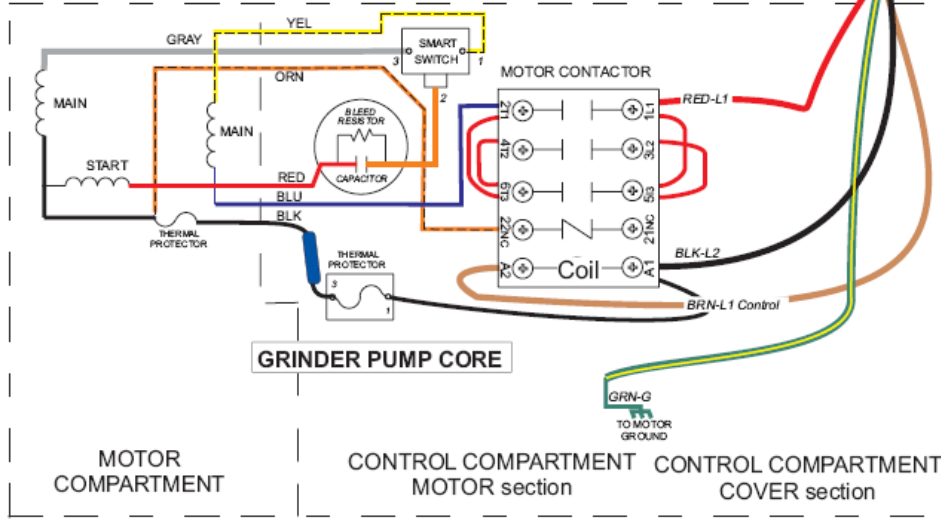

NA0036P11 B
240 Volt 60 Hz
Control Wiring Tag



Typical Pump Wiring Diagram – 240V 2-Leg (Extreme Wireless)

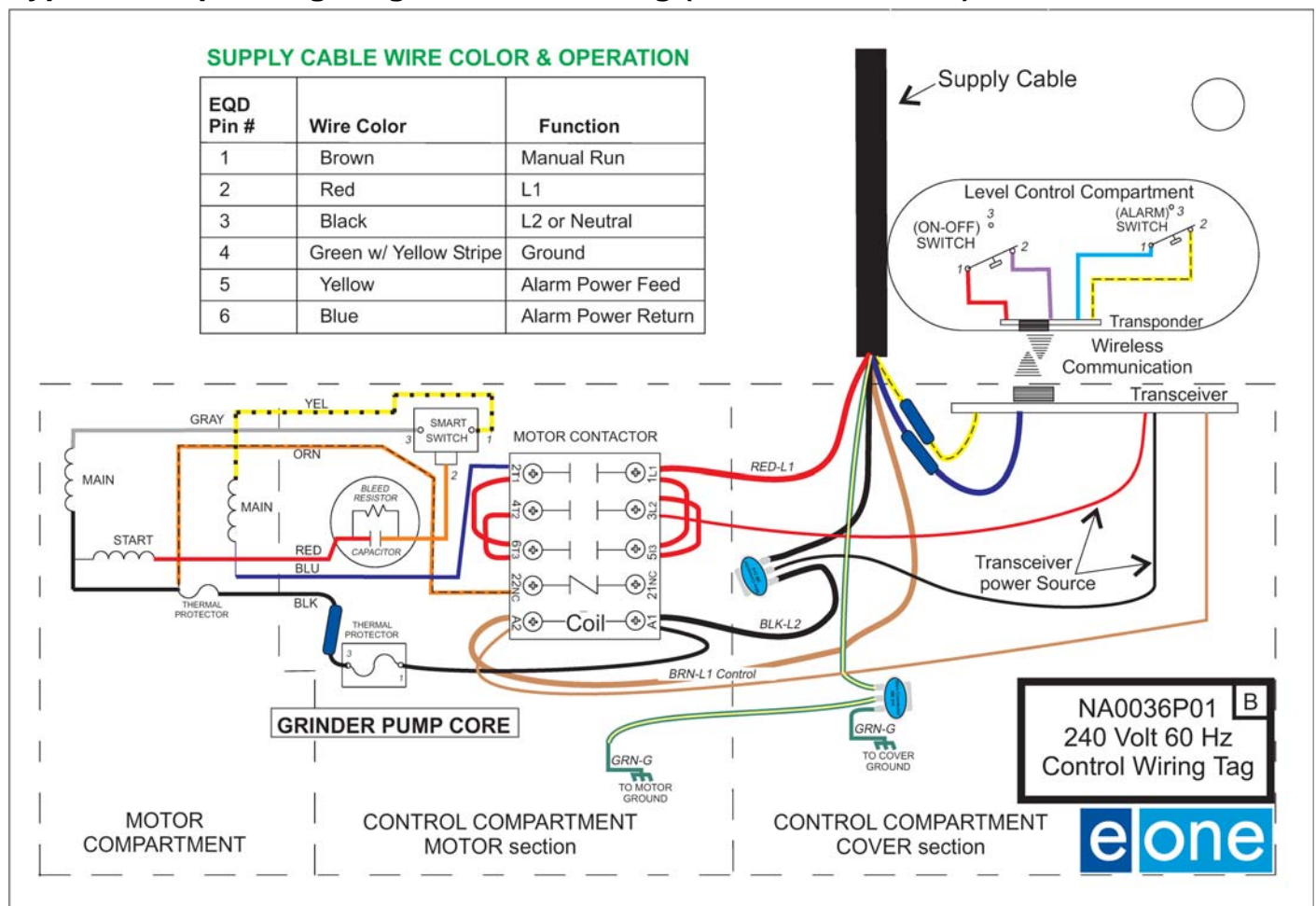

Trouble Shooting Panel Symptoms and Tests

- High Level Alarm will not turn on
 - What is the alarm time delay set at? Are you waiting long enough for the delay to pass?
 - Check the voltage between Yellow and Blue on the alarm board from the pump.
 - If the voltage is below 25 VAC check;
 - That the alarm board is fed the proper voltage between Service Neutral and Alarm BR L1.
 - Inspect supply cable and pump for problem.
 - If the voltage is above 25 VAC, the alarm pressure switch is open or there is a problem wire the wire connection between the panel and the pump.
- Volt and/or Amps do not read correctly
 - Check using a Volt/Amp meter to compare against the display.
 - To check the voltage, read the voltage directly off the Black and Red pump wires.
 - To check the amperage, check the current on the Black wire going to the pump.
 - If the readings are off more then 5% the Board assembly will need to be returned to the factory to be re-calibrated.

- Contactor in panel will not pull in
 - If voltage is 10% lower than nameplate voltage the contactor will not pull in.
 - Make sure all wire connections and terminals are torqued to their proper level.
 - Check the voltage coming into the panel.
 - If low repair it
 - Check the voltage between terminal TB7-2 (BR L1) and TB3-1 (NEUTRAL/BR L2)
 - If low repair it
- Manual run does not work
 - Check that all pump wires are properly connected and in the correct position.
 - Make sure the Red and Black pump wires are in their proper location.
 - With the manual run button pressed, read the voltage between the Black and Brown pump leads.
 - If the voltage read is within 10% of the pumps nameplate voltage, then there is either a problem in the supply cable or in the pump.
 - If the voltage read is low then remove the Brown wire.
 - Check the voltage between the Black pump wire and the terminal block where the Brown wire was removed. When pressing the manual run button nameplate voltage should be seen, if so the problem is a bad or shorted wire in the supply cable or in the pump.
- Pump running dry
 - Check the pump wires for shorts. Any shorts to the Brown wire (except from the pump Black wire) will need to be repaired.
- Pump will not run
 - Check the voltage between the Red and the Black pump wires.
 - If the voltage is normal, check the supply cable and/or the pump.
 - If there is no voltage, check to see if the Low Voltage Contactor is pulled in. The input voltage must be within 10% of nameplate voltage.
- LCD display is blank
 - Is the Alarm Breaker on? Is there power going to TB7-1 Alarm BR L1?
 - With power off to the Alarm Board (by turning off alarm and pump breakers), check the ribbon connection at the top of circuit board. It should be firmly connected.
 - With the power on to the Alarm Board, R1 (dial in upper left corner) can be adjusted with a small screwdriver to adjust the contrast of the LCD.

Technical Q&A (See Q&A document for complete list)

1. What do some of the major components on the Sentry Protect Plus circuit board do?
 - K3 is the changeover contacts; it supplies a connection to the indoor Remote Sentry from the Alarm Pressure Switch when there is no power or through a set of dry contacts on K4 when power is supplied.
 - K1 is the Redundant Run and the Dry Contact relay.
 - K5 is the Horn Silence relay.
 - K4 is the Remote Sentry Contact when power is supplied to the board.

- SSR1 is the solid state relay that controls the pump contactor
 - R1 is the LCD contrast control.
2. Why are both L1 and L2 going to the circuit board?
The panel needs L2 (which could also be Neutral in Australia and 120 volt panels) to operate the power measuring circuit when the pump operates.
 3. How exactly does the run indicator work?
The Sentry Protect Plus panel measures the amperage drawn by the pump. If the draw exceeds a pre-set value, the Pump Running indicator will light.

Appendix

Typical Panel Wiring Diagram – 240V 2-Leg

