

Catalog Number : 9T51B0129

Features :

- Line: 120 x 240 Vac
- Load: 16/32 Vac
- Single Phase, 0.75 kVA
- 100 degree rise, Copper
- Buck Boost Application
- No Electrostatic Shield
- QB, 60Hz

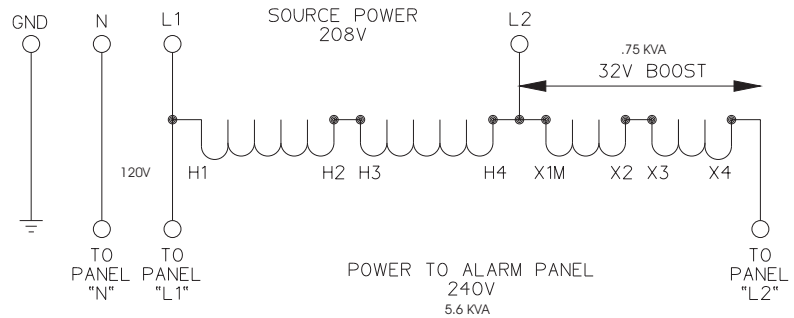

NOTE:
 PANEL "L1" IS THE ALARM CIRCUIT & PUMP BLACK WIRE
 PANEL "L2" IS THE PUMP CIRCUIT (THE WHITE WIRE)
 (REFER TO THE WIRING DECAL PROVIDED ON THE DOOR OF THE PANEL)

Dimensions (inches) : 9.62H x 7.88W x 5.5D x 25lbs

Buck-Boost Transformers.

Introduction

The Buck-Boost transformer is a very versatile product for which a multitude of applications exist. In its simplest form, these transformers will deliver 12, 16, 24 or 32 volts when their primaries are energized at 120 or 240 volts.

Their prime use, however, lies in the fact that the primaries and secondaries can be **interconnected**, thus permitting their use as an autotransformer. When the primaries and secondaries are connected together so that electrical characteristics are changed from a two winding transformer to those of an autotransformer, the units can economically 'buck or boost' voltage up to +/- 20%.

For use with e|one Duplex Panels

Single Phase Load: 16/32 Vac
 Non-Vented (NEMA 3R)
 Enclosure
 Buck Boost

ORDER NUMBER:
 PA0219P03

DR BY: SGS	DATE: 01/13/06	 ENVIRONMENT ONE CORPORATION TRANSFORMER, BUCK BOOST .75KVA, (E-ONE PT No. PA0219P03)	
CHKD BY:	DATE:		
ENG BY:	DATE:		
APPD BY:	DATE:		
SCALE: FULL		MATERIAL:	
		PART NUMBER:	PART
		LM000230	3
TYPE: 4	CLASS: 06	DWG NUMBER	SHEET 1 OF 1 REV