

SENTRY Protect Plus SIMPLEX PANEL Installation and Operation Manual For Wireless and Explosion Proof Pumps

Environment One Corporation



Table of Contents

1	Overview.....	3
2	Sentry Protect Plus Menu Flowchart	4
3	Wiring Instructions.....	5
3.1	Alarm Dry Contacts	5
3.2	Switch Over Dry Contacts – to be used with an E/One Remote Sentry (optional)	5
4	Startup.....	5
5	User Menus and LCD Display.....	5
5.1	Trouble History Log.....	6
6	System Initialization	7
6.1	Software Revision	7
6.2	DIP Switch.....	7
6.3	Brownout / Overvoltage Limits	7
6.4	Run Dry (Low Watts) Limits Setting – password protected.....	7
6.5	Overpressure (High Watts) Limits Setting – password protected.....	7
6.6	User Programmable Options.....	8
6.6.1	Cold Start.....	8
6.6.2	Clear Trouble	8
6.6.3	Alarm Latch Setting.....	8
6.6.4	Protect Mode Setting.....	8
6.6.5	Buzzer (audible alarm) Timer Setting	9
6.6.6	Data Push Enable Setting	9
6.6.7	Trouble Mode Setting	9
6.6.8	Explosion Proof Ready – for use with E/One Explosion Proof grinder pumps only.....	9
6.6.9	Restore Factory Defaults.....	10
6.6.10	Calibrate – password protected	10
6.6.11	Reset Calibration – password protected.....	10
6.6.12	Custom Settings.....	10
6.7	Run Limit Setting.....	11
6.8	Alarm Delay Setting	11
6.9	Power Delay Setting.....	12
7	Normal Operation	13
7.1	Manual Run Operation.....	13
7.2	High Level Alarm Operation	13
7.3	Trouble Alarm Indication	14
7.4	Audible Alarm Manual Silence	14
7.5	Pump Performance	14
7.5.1	Normal Hour Meter	14
7.5.2	Normal Cycle Counter	14
7.5.3	Manual Run Hour Meter	14
7.5.4	Manual Run Cycle Counter.....	14
7.5.5	Last Runtime.....	14
7.5.6	Minimum Runtime.....	14
7.5.7	Maximum Runtime	15
7.5.8	Average Runtime	15
7.5.9	Minimum Amps	15
7.5.10	Maximum Amps.....	15
7.5.11	Average Amps.....	15
7.5.12	Minimum Volts	15
7.5.13	Maximum Volts.....	15
7.5.14	Average Volts.....	15
7.5.15	Minimum Watts.....	15
7.5.16	Maximum Watts.....	15
7.5.17	Average Watts	15
7.5.18	Leak Detected (read-only leak indication field, E/One explosion proof pumps only)	15
7.5.19	Clear Counters (cycles, hour meters, averages).....	16
7.5.20	Clear Minimums and Maximums.....	16
7.5.21	Clock Error	16
8	Trouble Operation.....	16
8.1	Excessive Runtime Operation.....	16
8.2	Brownout Operation	16
8.3	Overvoltage Operation	16
8.4	Run Dry Operation	17
8.5	Overpressure Operation	17
8.6	Alarm Circuit Protection Active.....	17
8.7	Watt-meter Operation.....	18
8.8	Leak Detect Operation (E/One explosion proof pumps only).....	18
9	Diagnostics.....	18
9.1	LED Test	18
9.2	Button Test	18
9.3	Relay Test	18
10	Communication.....	18
10.1	Serial Interface.....	19
10.2	Sentry Advisor Option	19
11	Wireless and Explosion Proof Pump Operation	19
12	Trouble Shooting.....	20
12.1	Troubleshooting Chart	20
13	Appendix.....	22
13.1	System Parameters Memory Map.....	22
13.2	LCD Messages	23
13.3	Wiring Diagrams	24
13.3.1	240V, 2-leg basic panel wiring (for US installations)	24
13.3.2	240V, 2-leg optional panel wiring (for US installations).....	25
13.3.3	240V, 1-leg basic panel wiring (for non-US installations).....	26
13.3.4	240V, 1-leg with optional generator receptacle, manual transfer switch (for non-US installations).....	27

1 Overview

This manual provides information on the operation and use of Environment One Simplex Protect Plus Panels, and applies to panels configured with printed circuit board assembly P/N NB0189Gxx. For panel configurations beginning with 'SE3...' this manual applies to product with an approximate manufacture date of 10/2011 or later. For all other configurations this manual applies to product with an approximate manufacture date of 03/2012 or later. If unsure of the configuration of your panel, contact E/One factory for assistance.

The Sentry Protect Plus panel is an Environment One full-featured Alarm/Monitor panel. The Sentry Protect Plus panel monitors for the following operating conditions:

- Pump Run Dry Condition – Pump running out of water
- Pump Overpressure Condition – Pump operating at abnormally high wattage level
- Brownout Condition – Mains voltage under 12% of nameplate rating
- Overvoltage Condition – Mains voltage above 12% of nameplate rating
- High Liquid Level
- Real-time, High, and Low Voltage to the Pump
- Real-time, High, and Low Wattage drawn by the Pump
- Extended Pump Runtime (field programmable limit)

The Sentry Protect Plus Panel displays pump status, operating parameters, and user options by means of the following indicators:

- LCD Display to show Pump & Panel operating conditions
- Four Status Indicators:
 - Ready (Green LED)
 - Pump Running (Green LED)
 - Trouble (Amber LED)
 - High Level Alarm (Red LED)
- Eight Selectable Modes to view or change panel operation
- Menu Navigation Buttons – Enter, Scroll, Mode, ↑ 'A' and ↓ 'B'

In addition, the following pump operating parameters can be viewed from the Sentry Protect Plus Panel:

- Real-time pump Voltage, Amperage, and Wattage (power)
- Cycles & Hours (resettable)
- Minimum, Maximum, Average, and Last Run Cycle in Minutes (resettable)
- Minimum, Maximum and Average Voltage, Amperage, and Wattage (resettable)
- Leak Detection (for E/One explosion proof pumps only)
- Latched fault conditions

The following features are field programmable:

- Excessive Run Time
- Alarm On Delay
- Power On Delay

The following are the hardware features:

- IP65 / NEMA 4X Rated Enclosure
- Enclosure made from Thermoplastic Polyester
- Separate Alarm and Pump Circuit Breakers
- Audible & Visual Alarm indicators (Silence for Audible Alarm)
- Manual Pump Run Button
- Remote Sentry Alarm Dry Contacts – Normally Open, rated for 24VDC, 2A maximum (Can operate with or without power. Intended for use with Environment One Remote Sentry, sold separately)
- Alarm Dry Contacts – Normally Open (Requires alarm board to have power)

2 Sentry Protect Plus Menu Flowchart

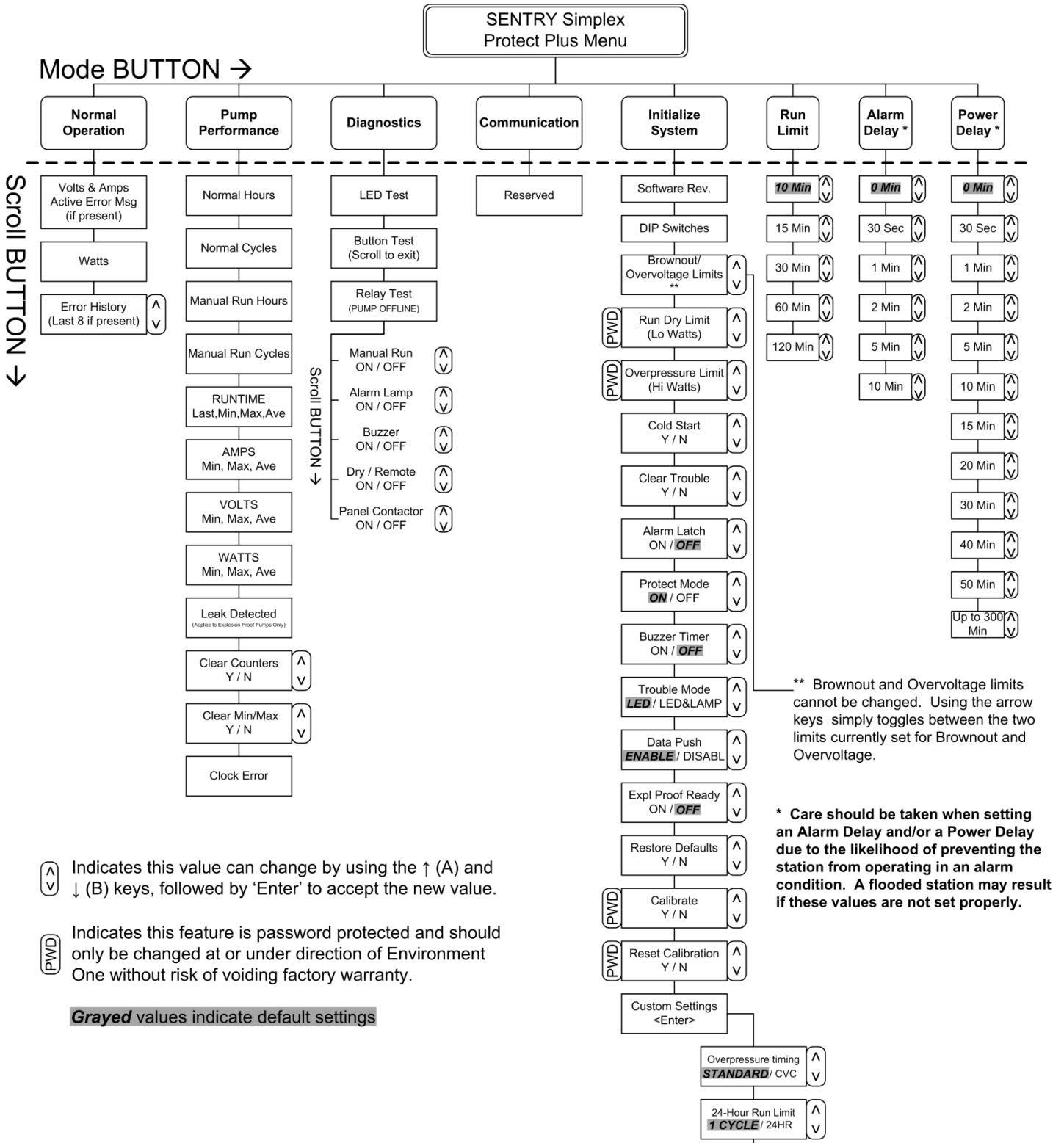

Custom Settings - Please refer to the setup instructions shipped with your panel (NA0168P02) for more details on this feature. These are also available at: www.eone.com/sewer_systems/catalog/alarm-panels/eone-sentry-protect-plus-panel.htm

Figure 1 – Menu Flowchart

3 Wiring Instructions

WARNING – the E/One Alarm and Control panel is a high voltage system that controls power to an electric motor. Care should be taken whenever performing service on the panel to avoid the risk of electrical shock and/or damage to property. Because power may be supplied by multiple sources, circuit breakers alone may not be sufficient to provide adequate protection.

Due to the many different optional features, the Sentry Protect Plus panel wiring can change from model to model. All wiring shall be done in accordance with the wiring decal on the inside cover of the panel enclosure.

Several examples of typical wiring can be found in the Appendix of this manual.

3.1 Alarm Dry Contacts

Warning! These dry contacts are capable of a maximum of 2A. Connections that exceed this maximum value can cause permanent damage to the printed circuit board within the panel.

The Sentry Protect Plus panel is equipped with one set of dry contacts that coincide with the following alarm indications:

High Water Level

Run Dry (after third failed re-try)

Overpressure (after third failed re-try)

These dry contacts will close upon detection of any of the above listed events and remain closed until the condition is removed or cleared. If the Alarm Latch option is set to 'ON', these dry contacts will also be latched until the condition is cleared. Refer to the [Alarm Latch](#) section of this manual for more information on this feature.

3.2 Switch Over Dry Contacts – to be used with an E/One Remote Sentry (optional)

Warning! These dry contacts are designed to be used in conjunction with an E/One Remote Sentry device, and are capable of a maximum of +24VDC and 2A. Connections that exceed these maximum values can cause permanent damage to the printed circuit board within the panel.

The Sentry Protect Plus panel is equipped with one set of switch over dry contacts. If power is applied to the panel these contacts respond just as the Alarm Dry Contacts described above. When connected to an E/One Remote Sentry, that device will respond with an audible and visual alarm in conjunction with above indicated alarm conditions. If power to the panel is lost these contacts are 'switched over' to connect directly to the alarm switch in the pump. In this configuration, the Remote Sentry device will respond with an audible and visual alarm any time the alarm switch closes, allowing the use of water even during a power outage. When power is restored to the panel, these dry contacts will switch back to their normal position. If used with a wireless or E/One explosion proof grinder pump, the remote sentry will indicate an alarm immediately when the power to the pump is lost; it will be unable to determine the state of the alarm switch as is the case with a hardwired pump. If the Alarm Latch option is set to 'ON', these dry contacts will also be latched until the condition is cleared. Refer to the [Alarm Latch](#) section of this manual for more information on this feature.

4 Startup

The Sentry Protect Plus Panel should arrive from the factory ready to operate. The panel is properly installed and started by following the steps below.

1. Mount and wire the panel per the instructions on the enclosure door.
2. 'Cold Start' the panel – refer to [Cold Start](#) section of this manual for more information.
3. If other than factory default settings are required, set all limits, delays, and operating modes. Factory default settings can also be restored via the user menu. (Refer to the [User Programmable Options](#) section of this manual for more on this feature).

5 User Menus and LCD Display

The Sentry Protect Plus panel includes a text-based user interface to navigate the various menus and select the user options (see Figure 2). Four system status LED's indicate the current pump status, and are controlled automatically by

the system to indicate the various conditions. These are 'Ready', 'Pump Running', 'Trouble' and 'High Level Alarm'. Eight Mode LED's are used for monitoring operating parameters and system setup. The Mode button will sequentially select the different modes and the Scroll button will navigate the specific menus under each mode. For user selectable options, the ↑ 'A' and ↓ 'B' keys can be used to change the current value, and the 'Enter' button is used to accept any new setting. The current setting for any option is the value that is displayed when that item is first displayed. For example, if scrolling to Run Limit, and the LCD initially displays "LIMIT= 0 Min", then 0 minutes is the current Run Limit setting. Any changes must use 'Enter' to accept the new value; otherwise the initial value is maintained.

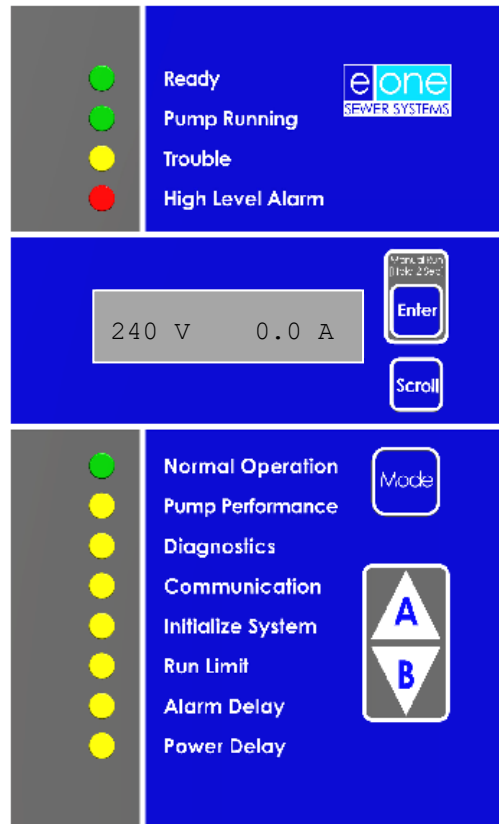

Figure 2 – User Interface Membrane Switch

The LCD display serves as an output from the panel to allow navigation through the menus and allows observation of real-time operating parameters. While in Normal Mode, the real-time voltage and amperage are simultaneously displayed. Pressing the Scroll button will display the real-time wattage of the pump. Pressing Scroll a second time will display Trouble History Log (see below). If there are no logged messages, the display reverts back to displaying the real-time voltage and amperage. Refer to the flow chart in [Figure 1](#) for an overview of the menu layout. At any time the LCD could display one of several messages to indicate a trouble condition. Refer to the [LCD Messages section](#) in the Appendix for a complete list of these messages and a brief description of what they mean.

5.1 Trouble History Log

The Trouble History Log stores the last 8 trouble events that have occurred beginning with the most recent. If the list contains at least one trouble message, the beginning of the list is identified by the LCD displaying the "Trouble History" heading for 1 second, followed by the most recent entry in the list. Pressing 'Scroll' will then sequence through subsequent items in the list from most recent to oldest. If the end of the list is reached, the display will 'wrap around' back to the top of the list which is again identified by the "Trouble History" heading. Within the list, the ↑ 'A' and ↓ 'B' keys can be used to move up and down the list. Whenever the top of the list is reached, the LCD will display the "Trouble History" heading. While displaying any trouble message in the list, pressing 'Enter' will display the Runtime of the pump that was active at the time the trouble event occurred. This is intended to provide a sort of timestamp of when the event occurred. This information can also indicate how frequently a trouble event is occurring when comparing to other items in the list. Pressing 'Enter' a second time will display the Cycles of the pump that was active at the time of the event. Like the Runtime, this is intended to provide information on when and how often a trouble event

is occurring. Every item in the list will contain these additional pieces of information to help provide an overview of the chain of events leading up to a particular trouble condition, to help with troubleshooting a problem.

6 System Initialization

A number of system settings, some of which will be unique to the installation, can be set on-site. Most of these settings can be found within the Initialize System mode; however Run Limit, Alarm Delay, and Power Delay each have their own mode for configuration. The following sections describe each of the items contained within the Initialize System mode.

6.1 Software Revision

This read only field displays the part number and revision of the software currently loaded into the panel. This information may be required when speaking with E/One service personnel.

6.2 DIP Switch

This read only field displays the setting of the four position miniature switch (DIP switch) located on the printed circuit board within the panel (labeled S1). These switches configure the Sentry Protect Plus for the operating environment in which the panel is being installed. From left to right, the first three positions configure the voltage setting as shown in the table below. The right most position is used to configure the panel for use with a wireless grinder pump (refer to the [Wireless and Explosion Proof Pump Operation](#) section of this manual for more information). In the following voltage selection table, “U” represents a switch in the Up (ON) position and ‘D’ represents a switch in the Down (OFF) position. The DIP switch must be programmed with power to the alarm board off (Alarm Breaker off). **While this setting is typically performed at the factory, it is essential that the DIP switch is properly set for the AC Mains voltage applied for the panel to operate properly.**

<u>Input Voltage</u>	<u>1 2 3 4</u>
240 VAC, 60 Hz	UUUX
240 VAC, 50 Hz	UUDX
230 VAC, 50 Hz	UDUX
120 VAC, 60 Hz	UDDX
200 VAC, 50 Hz	DUUX
RESERVED	DUDX, DDUX
Factory Use Only	DDDX

Warning! If DIP switch position 4 is not properly set for the type of pump, flooding of the station can occur. For switch position ‘4’ in all of the above settings, ‘X’ should be set to ‘D’ for hardwired pumps (factory default) or ‘U’ for wireless and E/One explosion proof pumps.

For wireless pumps, this setting disables the Redundant Run feature. The reason for this is that in a wireless pump, the circuit board in the pump itself can energize the Alarm Return signal for conditions other than just a high level alarm. Refer to the [Wireless and Explosion Proof Pump Operation](#) section of this manual for more information.

6.3 Brownout / Overvoltage Limits

This read-only field displays the limits that are currently set for both Brownout and Overvoltage. When in this menu, pressing the ↑ ‘A’ and ↓ ‘B’ keys will toggle between these two limits. These values cannot be changed.

6.4 Run Dry (Low Watts) Limits Setting – password protected

This field displays the limit that is currently set for the Run Dry / Low Watts protection feature. Though it is possible to change this setting, it is not advised unless directed by E/One service personnel, as changing this limit will affect how the protection feature performs. Doing so without proper guidance may void the product warranty and can cause damage to the system.

6.5 Overpressure (High Watts) Limits Setting – password protected

This field displays the limit that is currently set for the Overpressure / High Watts protection feature. Though it is possible to change this setting, it is not advised unless directed by E/One service personnel, as changing this limit will affect how the protection feature performs. Doing so without proper guidance may void the product warranty and can cause damage to the system.

6.6 User Programmable Options

The following items found within the Initialize System mode can be used for system setup.

6.6.1 Cold Start

The Cold Start option is found within the Initialize System mode. Cold Starting the panel erases all stored operating parameters listed within the Pump Performance mode as well as any latched fault condition and should be done when the panel is first installed. From the Cold Start menu, use the ↑ 'A' and ↓ 'B' keys to alternate the selection between 'N' (no) and 'Y' (yes). Once 'Y' is selected, press 'Enter' to accept; the panel asks 'Are You Sure?'. Pressing 'Enter' at this point will initiate a Cold Start of the panel (pressing 'Mode' or 'Scroll' will exit without Cold Starting). The LCD will display 'Cold Starting...', after which the panel will restart. All previously stored operating parameters will be cleared.

6.6.2 Clear Trouble

Clear Trouble is a user selectable feature that can be applied by using the 'Clear Trouble?' menu within the Initialize System mode. This feature allows the user to clear any latched fault conditions resulting from the following trouble conditions: Brownout, Overvoltage, Run Dry, Over Pressure, High Level Alarm, and Leak Detect. A latched fault condition is one that, despite the condition no longer being present, remains active, until cleared. From the Clear Trouble menu, use the ↑ 'A' and ↓ 'B' keys to alternate the selection between 'N' (no) and 'Y' (yes). Once 'Y' is selected, press 'Enter' to accept (pressing 'Mode' or 'Scroll' will exit without clearing); the LCD will display 'Clearing...'. Clear Trouble has no effect on any output that is active due to a present trouble condition.

6.6.3 Alarm Latch Setting

The Alarm Latch is a user selectable feature that can be set using the 'Alarm Latch' menu within the Initialize System mode. A latched Alarm means that, despite the alarm condition no longer being present, the indications associated with that alarm remain active indefinitely, until cleared. The following conditions are considered alarms and can be latched:

High Water Level

Run Dry (after third failed re-try)

Overpressure (after third failed re-try)

The factory default setting for this option is OFF. From the Alarm Latch menu, use the ↑ 'A' and ↓ 'B' keys to change the selection from 'N' (no) to 'Y' (yes). Once 'Y' is selected, press 'Enter' to accept the new value (pressing 'Mode' or 'Scroll' will exit without saving the change); the LCD will display 'Writing...'. If set to 'ON', this feature will cause the panel to latch all Alarm outputs except the Redundant Run feature. This includes the Alarm Lamp, High Level Alarm LED, Dry & Remote Sentry Contacts, and the audible alarm (Run Dry does not result in an audible alarm). The audible alarm will silence itself after a non-configurable set time of 10 minutes or can be silenced manually using the silence switch. All other outputs (contacts, indications, etc.) remain latched indefinitely until cleared. The condition can be cleared by using the 'Clear Trouble' option under the Initialize System menu or if the Alarm Latch Option is turned off and a subsequent Alarm event completes.

6.6.4 Protect Mode Setting

Warning! Setting this option to 'OFF' will revert the panel to a basic, non-protection mode, and should only be done as a last resort to keep the station functioning in a basic state for a short time until the station can be repaired.

The Protect option is a user selectable feature that can be cleared using the 'Protect' menu within the Initialize System mode. The factory default setting for this option is ON. From the Protect menu, use the ↑ 'A' and ↓ 'B' keys to alternate the selection between 'ON' and 'OFF'. Once the desired setting is selected, press 'Enter' to accept; the panel asks 'Are You Sure?'. Pressing 'Enter' will accept the new value (pressing 'Mode' or 'Scroll' will exit without saving the change); the LCD will display 'Writing...'. In the 'ON' position, the alarm panel will actively monitor Voltage, Amperage and Wattage and react to the following adverse operating conditions: Brownout, Overvoltage, Run Dry and Overpressure. This includes disabling the pump if any of the parameters are outside of the set limits (refer to the Trouble Operation section of this manual). If set to 'OFF', the panel will continue to monitor Voltage, Amperage & Wattage, however it will take no action if any of these parameters fall outside of their set limits. This option can be used in cases where the protect features are not working properly and are preventing the pump from operating despite no

out of limit conditions being present. Setting this option to 'OFF' will revert the panel to a non-protection mode until the panel can be repaired.

6.6.5 Buzzer (audible alarm) Timer Setting

The Buzzer Timer allows the audible alarm to automatically silence after a non-configurable time of 10 minutes; all other alarm indications will persist as long as the alarm is active. This option is a user selectable feature that can be set using the 'Buzzer Timer' menu within the Initialize System mode. The factory default setting for this option is OFF. From the Buzzer Timer menu, use the ↑ 'A' and ↓ 'B' keys to alternate the selection between 'ON' and 'OFF'. Once the desired setting is selected, press 'Enter' to accept the new value (pressing 'Mode' or 'Scroll' will exit without saving the change); the LCD will display 'Writing...'. If set to 'ON', this feature will silence the audible alarm after a non-configurable set time of 10 minutes. If the alarm condition terminates or the manual silence is pressed before the buzzer timer has expired, the audible alarm will silence without having reached the end of the 10 minutes. This timer resets to 10 minutes after an alarm has cleared.

6.6.6 Data Push Enable Setting

The Data Push is a feature used only with panels equipped with the Advanced Data option of the E/One Sentry Advisor Remote Monitoring System, or an equivalent SCADA system capable of interpreting the serial data transmitted from the panel. This feature allows all registers stored locally within the panel to be transmitted out over the Sentry Advisor System in response to a pump run cycle. These registers store all information regarding pump performance, system status, as well as user settings to allow viewing these parameters remotely. Refer to the [System Parameters Memory Map](#) section of this manual for more detail on the registers that are transmitted with the Data Push feature. The factory default setting for this option is ENABLE. From the Data Push menu, use the ↑ 'A' and ↓ 'B' keys to alternate the selection between 'ENABLE' and 'DISABL'. Once the desired setting is selected, press 'Enter' to accept the new value (pressing 'Mode' or 'Scroll' will exit without saving the change); the LCD will display 'Writing...'. If set to 'ENABLE', this feature will result in all registers being transmitted as a single data packet approximately 10 seconds after the start of each pump run cycle.

6.6.7 Trouble Mode Setting

The Trouble Mode is a user selectable feature that can be set using the 'Trouble' menu within the Initialize System mode. The factory default setting for this option is LED ONLY. In this position, any trouble alarm will be indicated only by the Trouble LED. From the Trouble Mode menu, use the ↑ 'A' and ↓ 'B' keys to change the selection from 'LED ONLY' to 'LED/LAMP'. Once the desired setting is selected, press 'Enter' to accept the new value (pressing 'Mode' or 'Scroll' will exit without saving the change); the LCD will display 'Writing...'. In the LED/LAMP position, any trouble alarm will be indicated by the Trouble LED as well as a flashing alarm lamp. Trouble alarms are triggered by the following:

- Brownout**
- Overvoltage**
- Excessive Run Time Limit**
- Run Dry (Trouble for first 3 re-tries, then Alarm)**
- Overpressure (Trouble for first 3 re-tries, then Alarm)**
- Faulty Watt-meter**
- Leak Detect (Expl. Proof pumps only)**

For Run Dry and Overpressure, only the first three occurrences are considered trouble events, after which they become alarms. Refer to their respective sections of this manual for how these conditions affect the Trouble LED and Alarm Lamp.

6.6.8 Explosion Proof Ready – for use with E/One Explosion Proof grinder pumps only

The Explosion Proof Ready option is a user selectable feature that can be set using the 'Expl Proof Ready' menu within the Initialize System mode, and is used to configure the panel to work with an Explosion Proof grinder pump. The factory default setting for this option is OFF and should remain off for all pumps that are not equipped with explosion proof protection measures. If the panel is to be used with an E/One Explosion Proof grinder pump, this setting should be switched to 'ON'. From the Expl Proof Ready menu, use the ↑ 'A' and ↓ 'B' keys to alternate the selection between 'ON' and 'OFF'. Once the desired setting is selected, press 'Enter' to accept the new value (pressing 'Mode' or 'Scroll'

will exit without saving the change); the LCD will display 'Writing...'. When in the ON position, the panel will evaluate an Alarm signal from the pump to determine if it is an actual High Level Alarm or if it is a Leak Detect signal indicating moisture intrusion to the motor or control compartments (refer to the [Wireless and Explosion Proof Pump Operation](#) section of this manual for more information). During this evaluation, an actual high level alarm will be delayed ~4 seconds, as will all outputs associated with an alarm, including: Alarm Lamp, Audible Alarm, Dry & Remote Sentry contacts, and High Level Alarm LED indicator. The Redundant Run activation will occur immediately, as it is under control of the core (pump) in a wireless pump. Refer to the [Wireless and Explosion Proof Pump Operation](#) section of this manual for more information. If the Explosion Proof Ready option is inadvertently left in the OFF position while paired with an E/One explosion proof grinder pump, the alarm indication will continue to work normal. However, if a Leak Detect is present, all alarm outputs mentioned above will be activated for ~3 seconds and then go off. Setting the Explosion Proof option appropriately will prevent this from occurring. Refer to the [Leak Detect Operation](#) section of this manual for more information. If this setting is not set correctly however, the panel will recognize the first time a Leak Detect signal occurs, and set the Explosion Proof option accordingly. If this option is set to ON, it is important to set the DIP switches for wireless operation as well. Refer to the [DIP Switch](#) section of this manual for more on this feature.

6.6.9 Restore Factory Defaults

The Restore Defaults option is a user selectable feature that can be applied by using the 'Restore?' menu within the Initialize System mode. From the Restore menu, use the ↑ 'A' and ↓ 'B' keys to alternate the selection between 'N' and 'Y'. Once 'Y' is selected, press 'Enter' to restore the factory default settings (pressing 'Mode' or 'Scroll' will exit without restoring); the LCD will display 'Restoring...'. Restoring the factory default values returns the following fields to their factory preset conditions [factory default]: Run Dry Limit [based on DIP Switch setting], Overpressure Limit [based on DIP Switch setting], Alarm Latch [OFF], Protect Mode [ON], Audible Alarm Timer [OFF], Trouble Mode [LED ONLY], Data Push Enable [ENABLE], Explosion Proof [OFF], Run Limit [10 MINUTES], Alarm Delay [NONE], and Power Delay [NONE].

6.6.10 Calibrate – password protected

Calibrate is a **factory only** feature that is located in the 'Calibrate?' menu within the Initialize System mode. Calibration is performed at the factory and is necessary to provide the system with baseline Voltage, Amperage, and Wattage settings. The process uses a special fixture capable of applying highly accurate values to the system. Once applied, a calibration measurement is taken to establish reference values for these operating parameters. Performing a calibration without the proper equipment will cause the system to malfunction and is not to be performed by anyone outside of factory personnel.

6.6.11 Reset Calibration – password protected

The Reset Calibration option is a user selectable feature that can be applied by using the 'Reset Cal?' menu within the Initialize System mode. **Reset Calibration should only be performed if it is known that the factory calibration has been compromised. Refer to the troubleshooting guide at the back of this manual for more information on making this determination.** Performing a reset cal will reset the calibration settings to default values, which may not be precisely correct for a specific panel, but should be adequate to allow the system to temporarily function until the panel can be repaired.

CAUTION: This should only be done as a last resort if the panel is non-operational, and until the panel can be repaired. This will allow the panel to perform its protect function, but the set limits may not be highly accurate.

6.6.12 Custom Settings

The Custom Settings menu contains features that were not standard on the original release of the Protect Panel, but were either requested by a specific job or suggested generally as being a useful feature to add. This allows the addition of newer options that may arise as the product matures with minimal changes to other product documentation. This sub-menu is available via the 'Custom Settings' menu within the Initialize System mode. Pressing 'Enter' from the 'Custom Settings' menu will open a new list of additional features that may be added to from time to time by Environment One. This menu can be navigated using the 'Enter', 'Scroll', ↑ 'A' and ↓ 'B' keys just as any other menu. Pressing 'Mode' will return to the Initialize System mode.

While this manual is intended to be updated periodically to reflect all such additions to the Custom Settings menu, it is possible that items have been added that are not reflected herein. Check the website for the latest version of this manual, or the installation instructions that were shipped with the panel (NA0168P02, also available on the website), for the most up to date information.

6.6.12.1 OP (Overpressure) Timing Mode

This option provides an alternate method for retrying to start the motor after an Overpressure Lockout. Refer to the paragraph on [Overpressure](#) in the Trouble Operation section of this manual for more on this feature.

The OP Timing Mode is a user selectable feature that can be set using the 'OP Mode:' menu within the Custom Settings section of the Initialize System mode. The factory default setting for this option is Standard. From the OP Mode menu, use the ↑ 'A' and ↓ 'B' keys to alternate the selection between 'Standard' and 'CVC'. Once the desired setting is selected, press 'Enter' to accept the new value (pressing 'Mode' or 'Scroll' will exit without saving the change); the LCD will display 'Writing...'. If set to 'Standard', the lockout / re-try timing for an Overpressure event consists of 3, 20-minute lockout cycles with a re-try of the pump after each lockout. 'CVC' is a custom setting where the lockout / re-try timing consists of 4, 30-minute, followed by 6, 60 minute lockout cycles with a re-try of the pump after each lockout. In either case, after the final failed attempt, the pump is disabled indefinitely until power is reset.

6.6.12.2 24-hour Run Limit

This setting works in conjunction with the Run Limit Mode and provides an alternate method for determining a Run Time Alarm based on the duration set for that feature. Refer to the [Run Limit](#) section of this manual for more on this feature.

The 24-hour Run Limit is a user selectable feature that can be set using the 'Run Limit:' menu within the Custom Settings section of the Initialize System mode (separate from the Run Limit Mode which is explained in the following section). The factory default setting for this option is 1 Cyc (1 pump run cycle). From the Run Limit menu, use the ↑ 'A' and ↓ 'B' keys to change the selection from '1 Cyc' to '24Hr'. Once the desired setting is selected, press 'Enter' to accept the new value (pressing 'Mode' or 'Scroll' will exit without saving the change); the LCD will display 'Writing...'. If set to '1Cyc', this feature will issue a trouble alarm for an excessive runtime based on the duration of a single pump cycle. If set to '24Hr', the trouble alarm for a Run Time Alarm will be based on the accumulated runtime of all pump cycles over a 24-hour period, beginning with when the option is first set.

6.7 Run Limit Setting

The Run Limit option is a user selectable feature that can be set from the Run Limit mode. The factory default setting for this feature is 10 minutes. This feature will cause a trouble alarm to be initiated if an individual pump run cycle exceeds the set value (assumes 24-hour Run Limit is set to 1 cyc). For an alternate way to configure this feature, refer to the [24-hour Run Limit](#) section of this manual. ***This feature only indicates a trouble alarm; it does not disable the pump.***

Using the 'Enter', 'Scroll', ↑ 'A' and ↓ 'B' keys, the Run Limit can be set to any value between 10 and 120 minutes. For convenience, the following presets have been programmed:

- 10 minutes
- 15 minutes
- 30 minutes
- 60 minutes
- 120 minutes

'Scroll' will step through this list of preset values, while ↑ 'A' and ↓ 'B' will increase or decrease the current value in 1 minute increments. Once the desired value is reached, pressing 'Enter' will commit the value to memory (pressing 'Mode' or 'Scroll' will exit without saving the change).

6.8 Alarm Delay Setting

Caution should be exercised when setting this option as ALL Alarm indications from the station will be delayed for the duration selected. Flooding of the station may occur if water is used beyond the point at which an

alarm has occurred, and no alarm indications are present to warn the user of the high level. Use of this option is only recommended in cases where sufficient capacity will prevent flooding!

The Alarm Delay option is a user selectable feature that can be set from the Alarm Delay mode. The factory default setting for this feature is 0 minutes (No Delay). This feature will cause all indications associated with a High Level Alarm to be delayed by the selected time except the High Level Alarm LED and the Alarm Lamp. The LED will light immediately and remain on during a high level alarm condition and the Alarm Lamp will blink for the duration of the delay. Delayed indications include the Audible Alarm, Dry & Remote Sentry Contacts, and Redundant Run Relay activation. During an Alarm Delay, 'Delayed Alarm' will be displayed on the LCD to indicate the condition.

Using the 'Enter', 'Scroll', ↑ 'A' and ↓ 'B' keys, the Alarm Delay can be set to any value between 0 and 10 minutes. For convenience, the following presets have been programmed:

- 0 minutes (No Delay)
- 30 seconds
- 1 minute
- 2 minutes
- 5 minutes
- 10 minutes

'Scroll' will step through this list of preset values, while ↑ 'A' and ↓ 'B' will increase or decrease the current value in 1 minute increments. Once the desired value is selected, press 'Enter' to accept the change. The panel asks 'Are You Sure?' at which time pressing 'Enter' will commit the value to memory (pressing 'Mode' or 'Scroll' will exit without saving the change).

6.9 Power Delay Setting

A power delay can be set to stagger the startup times within a group of pumps after power is restored following a power outage. By default, a high level alarm will cause a redundant run of the pump regardless of any pre-set power delay.

Caution should be exercised when setting this option as power to the pump will be delayed for the duration selected. Flooding of the station can occur if this option is not set properly. Use of this option is only recommended in cases where sufficient capacity will prevent flooding!

The Power Delay option is a user selectable feature that can be set from the Power Delay mode. The factory default setting for this feature is 0 minutes (No Delay). This feature will cause power to the pump to be disabled after application of power to the panel for the duration determined by the set value.

Using the 'Enter', 'Scroll', ↑ 'A' and ↓ 'B' keys, the Power Delay can be set to any value between 0 and 120 minutes. For convenience, the following presets have been programmed:

- 0 minutes (No Delay)
- 30 seconds
- 1 minute
- 2 minutes
- 5 minutes
- 10 minutes
- 15 minutes
- 20 minutes
- 30 minutes
- 40 minutes
- 50 minutes

'Scroll' will step through this list of preset values, while ↑ 'A' and ↓ 'B' will increase or decrease the current value in 1 minute increments. Once the desired value is selected, press 'Enter' to accept the change. The panel asks 'Are You Sure?' at which time pressing 'Enter' will commit the value to memory (pressing 'Mode' or 'Scroll' will exit without saving the change). If a Power Delay is active, the LCD will display "POWER DELAY" alternating with the remaining delay time and the Ready LED will blink. If during a power delay a high level alarm is detected, the alarm will be indicated by

the Alarm Lamp, Dry & Remote Sentry Contacts, High Level Alarm LED indicator, and the Ready LED will continue to blink indicating that a Power Delay is still active. In addition, the Redundant Run circuit will force the pump to operate. For service, a Power Delay can be over-ridden by pressing the Manual Run ('Enter') button.

7 Normal Operation

Under normal operating conditions, the Sentry Protect Plus panel will perform as follows when power is applied:

1. During the boot-up period, all panel indications and outputs will be OFF except for the Alarm Lamp, the Panel Contactor, and the Normal Operation Mode LED. The LCD will display "ENVIRONMENT ONE!" followed by the part number and revision level of the installed software, for approximately 2 seconds.
During this boot up sequence, all operating parameters are recovered from non-volatile memory. If this is the first time the panel has been started, these will be the factory defaults and all operating parameters will be 0. Otherwise, these values will be what they were the last time the panel operated. If the panel requires a reset to restore factory defaults, refer to the [Restore Factory Defaults](#) feature in the Initialize System section of this manual. In addition, a Cold Start may be needed to clear out the Pump Performance operating parameters; refer to the [Cold Start](#) feature within the Initialize System section of this manual.
2. When the boot-up sequence is complete and the voltage has settled to an acceptable level, the Alarm Lamp will turn off.
If a Power Delay has been set, that delay must expire before power will be provided to the pump. In this case, the LCD will display "POWER DELAY", alternating with a countdown of the remaining delay time, and the green Ready LED will blink for the duration of the delay.
Once the boot-up sequence is complete and the power delay has expired (if applicable), the green Ready LED will light steady and the panel is in a normal operating mode and ready for operation.
3. Under normal conditions, the LCD will display the real-time Volts and Amps at all times. Pressing the 'Scroll' button will display the pumps operating Wattage. Pressing 'Scroll' a second time will display any latched error message if one exists. If no error message is latched, the LCD will return to displaying the Volts and Amps.
4. The green Pump Running LED will light any time the pump is operating (a delay of approximately 1-2 seconds will occur from the time the motor actually starts/stops, until the LED reacts; this is the time the panel takes to confirm the state of the motor).
5. After each completed pump run cycle, the Pump Performance parameters are updated to reflect the most current data. Refer to the [Pump Performance](#) section of this manual for more on this feature.

7.1 Manual Run Operation

The pump can be operated manually (provided there are no detected trouble conditions that would prevent it from running) by pressing and holding the Manual Run ('Enter') button on the dead-front overlay. The Pump Running LED will light and the pump voltage, amperage and wattage will be available on the LCD.

Note that it may take a few seconds for the Manual Run button to turn on the pump and Pump Running LED.

Releasing the button will stop the pump.

7.2 High Level Alarm Operation

A High Level Alarm is initiated if the liquid level in the tank reaches the high level as determined by the Alarm pressure switch. If a High Level is detected, the panel will indicate an alarm, including the Alarm Lamp, Audible Alarm, High Level Alarm LED, High Level Alarm LCD message, Dry and Remote Sentry Contacts, and the Redundant Run circuit that will force the pump to operate, unless an Alarm Delay is set. All indications except the LCD message will self-clear once the level in the tank falls below the preset limit of the Alarm pressure switch, unless the Alarm Latch option is set to ON. The LCD message will remain latched until a subsequent error is detected.

7.3 Trouble Alarm Indication

Conditions that do not warrant immediate attention are indicated by a Trouble Alarm. These conditions are:

- Brownout**
- Overvoltage**
- Excessive Run Time Limit**
- Run Dry (Trouble for first 3 re-tries, then Alarm)**
- Overpressure (Trouble for first 3 re-tries, then Alarm)**
- Faulty Watt-meter**
- Leak Detect (Expl. Proof pumps only)**

A Trouble Alarm is indicated by the Trouble LED, and if selected via the Trouble Mode feature, a blinking Panel Alarm Lamp; refer to the [Trouble Mode](#) feature in the User Programmable Options section above on setting this option. The following conditions will result in a Trouble Alarm: Excessive Runtime, Brownout, Overvoltage, Leak Detect (for E/One Explosion Proof Pumps), and initial Run Dry and Overpressure indications. Refer to the [Trouble Operation](#) section of this manual for more on these features.

7.4 Audible Alarm Manual Silence

Anytime the audible alarm / buzzer is activated by the system, it can be silenced by pressing the 'SILENCE' button located on the exterior underside of the enclosure.

7.5 Pump Performance

When power is first applied to the panel, the Normal Operation is the default mode, as indicated by the green LED adjacent to Normal Operation being illuminated. While in the Normal Operation Mode the real-time operating voltage and amperage will be displayed on the LCD screen simultaneously. Pressing the 'Scroll' button one time will display the real-time operating wattage. After each completed Pump Run cycle, all operating parameters are updated with the most recent data. If power is lost during a Pump Run cycle, only data for that cycle will be lost, all other data is maintained in non-volatile memory.

Pressing the 'Mode' button until the LED adjacent to Pump Performance is illuminated will display several other system operating parameters. The following are displayed under Pump Performance:

7.5.1 Normal Hour Meter

Accumulated runtime - The time is displayed as **Run: HH:MM:SS**, where HH are the total hours, MM minutes, and SS seconds since the last reset. The maximum runtime value that can be stored is 999999:59:59 (> 114 years). Beyond this limit the value automatically resets to 00:00:00.

7.5.2 Normal Cycle Counter

Accumulated cycles - The value is displayed as **Cycles: XX**, where XX are the total accumulated pump cycles since the last reset. The maximum cycle value that can be stored is 1 billion. Beyond this limit the value automatically resets to 0.

7.5.3 Manual Run Hour Meter

Accumulated Manual Run runtime - For service and troubleshooting purposes, the Manual Run hours are tracked separately from normal hours. This value is displayed as **MR: HH:MM:SS** and has the same limits as the normal hours.

7.5.4 Manual Run Cycle Counter

Accumulated Manual Run cycles - For service and troubleshooting purposes, the Manual Run cycles are tracked separately from normal cycles. This value is displayed as **MR Cycles: XX** and has the same limits as the normal cycles.

7.5.5 Last Runtime

Last runtime represents the duration of the previous completed pump cycle. This value is displayed as **Last Run: XXXs**, where XXX is the last runtime duration in seconds.

7.5.6 Minimum Runtime

The minimum runtime represents the duration of the shortest completed pump cycle since the last reset. This value is displayed as **Min Run: XXXs**, where XXX is the minimum runtime duration in seconds.

7.5.7 Maximum Runtime

The maximum runtime represents the duration of the longest completed pump cycle since the last reset. This value is displayed as **Max Run:HH:MM:SS** and has the same limits as the normal hours.

7.5.8 Average Runtime

The average runtime represents the duration of the average completed pump cycle since the last reset. This value is displayed as **Ave Run: XXXs** where XXX is the average runtime duration in seconds.

7.5.9 Minimum Amps

The minimum Amperage reading represents the minimum amperage draw the motor has experienced while running since the last reset. This value is displayed as **Min Amps: X.XA** where X.X is the minimum Amperage to the nearest tenth.

7.5.10 Maximum Amps

The maximum Amperage reading represents the maximum amperage draw the motor has experienced while running since the last reset. This value is displayed as **Max Amps: X.XA** where X.X is the maximum Amperage to the nearest tenth.

7.5.11 Average Amps

The average Amperage reading represents the average amperage draw the motor has experienced while running since the last reset. This value is displayed as **Ave Amps: X.XA** where X.X is the average Amperage to the nearest tenth.

7.5.12 Minimum Volts

The minimum Voltage reading represents the minimum voltage the motor has experienced while running since the last reset. This value is displayed as **Min Volts: XV** where X is the minimum Voltage to the nearest volt.

7.5.13 Maximum Volts

The maximum Voltage reading represents the maximum voltage the motor has experienced while running since the last reset. This value is displayed as **Max Volts: XV** where X is the maximum Voltage to the nearest volt.

7.5.14 Average Volts

The average Voltage reading represents the average voltage the motor has experienced while running since the last reset. This value is displayed as **Ave Volts: XV** where X is the average Voltage to the nearest volt.

7.5.15 Minimum Watts

The minimum Wattage reading represents the minimum Wattage the motor has experienced while running since the last reset. This value is displayed as **Min Watts: XW** where X is the minimum Wattage to the nearest watt.

7.5.16 Maximum Watts

The next maximum Wattage reading represents the maximum Wattage the motor has experienced while running since the last reset. This value is displayed as **Max Watts: XW** where X is the maximum Wattage to the nearest watt.

7.5.17 Average Watts

The average Wattage reading represents the average Wattage the motor has experienced while running since the last reset. This value is displayed as **Ave Watts: XW** where X is the average Wattage to the nearest watt.

7.5.18 Leak Detected (read-only leak indication field, E/One explosion proof pumps only)

The leak detect indication only applies to E/One Explosion Proof pump installations. This field indicates that a leak has been detected in the motor or control compartment. While a Leak Detect is recognized as a Trouble Alarm with a corresponding 'Leak Detected' LCD message, it is possible that it may have been over written by a subsequent higher priority alarm. This field is meant to preserve the occurrence of a leak detect in this event. If leak detection is a requirement for the installation, this field can be checked periodically to verify no leak has occurred. Clearing this condition requires removing the leak condition.

7.5.19 Clear Counters (cycles, hour meters, averages)

The clear counters option can be used to clear the following pump parameters: Normal Hours, Normal Cycle Counter, Manual Run Hours, Manual Run Cycle Counter, Last Run Time, Average Volts, Average Amps and Average Watts. From the Clear Counters menu, use the ↑ 'A' and ↓ 'B' keys to alternate the selection between 'N' (no) and 'Y' (yes). Once 'Y' is selected, pressing 'Enter' will clear the stored values.

7.5.20 Clear Minimums and Maximums

The clear minimum and maximum option can be used to clear the following pump parameters: Minimum and Maximum Volts, Minimum and Maximum Amps, Minimum and Maximum Watts, and Minimum and Maximum Run Time. From the Clear Min/Max menu, use the ↑ 'A' and ↓ 'B' keys to alternate the selection between 'N' (no) and 'Y' (yes). Once 'Y' is selected, pressing 'Enter' will clear the stored values.

7.5.21 Clock Error

The clock error field indicates that there is a problem with the board's microprocessor timing. If this is the case, this field will display 'Clock Error: 1', otherwise it will show 'Clock Error: 0'. This is a self clearing error. If this field is set to a '1', factory service should be contacted. This condition does **not** result in a trouble indication or LCD message and can only be verified by navigating to the Clock Error field within the Pump Performance mode.

8 Trouble Operation

Several less serious operating conditions can be detected and indicated to warn of pending, more serious faults. These conditions do not warrant an immediate response and may clear themselves given time. These conditions are:

Brownout

Overvoltage

Excessive Run Time Limit

Run Dry (Trouble for first 3 re-tries, then Alarm)

Overpressure (Trouble for first 3 re-tries, then Alarm)

Faulty Watt-meter

Leak Detect (Expl. Proof pumps only)

For these events, a trouble alarm is indicated by the Trouble LED and a corresponding error message on the LCD is available by pressing the 'Scroll' button two times to navigate to the fault message. The Alarm Lamp can also be set to flash in these cases by setting the Trouble Mode option (refer to the [Trouble Mode](#) option under the User Programmable Options section of this manual for more on this feature).

8.1 Excessive Runtime Operation

Excessive Runtime is an alarm that is initiated if an individual pump run cycle exceeds the set Run Limit value. If the Run Limit is exceeded, the panel will indicate a trouble alarm as determined by the Alarm Mode setting. In addition, the amber Trouble LED will light and a corresponding error message will be displayed on the LCD screen. This alarm serves only as a visual indicator that this limit has been exceeded; operation of the pump is not affected.

8.2 Brownout Operation

Brownout is a motor protection feature that will disable power to the motor if the incoming AC Mains Voltage is below a predefined limit, typically 12% of the nominal nameplate rating. In the brownout mode, the pump is prevented from starting (if the pump is off), or is shut off (if the pump is running) until the voltage returns to within the desired range of operation, typically 10% of the nominal nameplate rating. When in the Brownout Protection mode, the panel will disable power to the pump, whether the motor is running or not and indicate a trouble alarm as determined by the Alarm Mode setting. In addition, the amber Trouble LED will light and a corresponding error message will be displayed on the LCD screen.

8.3 Overvoltage Operation

Overvoltage is a motor protection feature that will disable power to the motor if the incoming AC Mains Voltage is above a predefined limit, typically 12% of the nominal nameplate rating. In the Overvoltage mode, the pump is prevented from starting (if the pump is off), or is shut off (if the pump is running) until the voltage returns to within the

desired range of operation, typically 10% of the nominal nameplate rating. When in the Overvoltage Protection mode, the panel will disable power to the pump, whether the motor is running or not and indicate a trouble alarm as determined by the Alarm Mode setting. In addition, the amber Trouble LED will light and a corresponding error message will be displayed on the LCD screen.

8.4 Run Dry Operation

Run Dry is a motor protection feature that will disable power to the motor if the power consumption falls below a predefined limit. The factory default limit is based on the DIP switch settings and may vary for different locations. Refer to the [Run Dry](#) (Low Watts) menu within the Initialize System mode to see what the current value for this setting is. Contact E/One if you require more information on this setting. This limit is affected by the incoming AC Mains Voltage; as the Voltage fluctuates from nominal, this limit is automatically adjusted in order to obtain the same perceived pump power as would be seen at nominal Voltage. In addition, this value can be changed **under direction of the factory** to accommodate various system variables. When a Run Dry condition is detected, the pump is shut off and a 20 minute lockout period begins. During this time, the Trouble LED is illuminated, the Run Dry error message is displayed on the LCD and the pump is not allowed to run. After the 20 minute lockout, the pump is allowed to run; if the Run Dry condition is still present, a second lockout period begins and the cycle will repeat. During the first three lockout periods, the panel will indicate a Trouble Alarm (refer to the [Trouble Alarm](#) option within the Normal Operation section of this manual for more information on this feature). If after the third lockout period (60 minutes) the condition has not been removed and the pump attempts to start, the panel will indicate an alarm condition including the Alarm Lamp, Trouble LED, Dry and Remote Sentry contacts, but no Audible Alarm. The pump is retested every 20 minutes indefinitely and will self clear if a full pump cycle completes under normal conditions. If a High Level Alarm is detected at any time during the above process, the panel will respond by issuing a high level alarm (after any pre-set delay), including activating a redundant run to turn on the pump. It is assumed that if a high level alarm is present, despite the Run Dry condition there is liquid in the tank and a high level alarm / redundant run is necessary.

8.5 Overpressure Operation

Overpressure is a motor protection feature that will disable power to the motor if the power consumption rises above a predefined limit. The factory default limit is based on the DIP switch settings and may vary for different locations. Refer to the [Overpressure](#) (Hi Watts) menu within the Initialize System mode to see what the current value for this setting is. This limit can be changed **under direction of the factory** to accommodate various system variables. When an Overpressure condition is detected, the pump is shut off and a 20 minute lockout period begins. During this time, the Trouble LED is illuminated, the Overpressure error message is displayed on the LCD and the pump is not allowed to run regardless of the liquid level in the tank. After the 20 minute lockout, the pump is allowed to run; if the Overpressure condition is still present a second lockout period begins, and the cycle will repeat. During the first three lockout periods, the panel will indicate a Trouble Alarm (refer to the [Trouble Alarm](#) option within the Normal Operation section of this manual for more information on this feature). If after the third lockout period (60 minutes) the condition has not been removed and the pump attempts to start, the panel will indicate an alarm condition including the Alarm Lamp, Trouble LED, Dry and Remote Sentry contacts, and Audible Alarm. In addition, unlike for a Run Dry condition, in Overpressure the pump will not be retested every 20 minutes indefinitely because of the buildup of pressure that occurs during each retest. After the third failed retry, the pump is disabled indefinitely until it can be serviced. If a High Level Alarm is detected at any time during the lockout sequence, the panel will respond by issuing a high level alarm (after any pre-set delay), **but will not issue a redundant run.**

In either a Run Dry or an Overpressure condition, a 20 minute lockout period can be bypassed by pressing the Manual Run button ('Enter'). This should only be performed by E/One Certified Service Personnel.

8.6 Alarm Circuit Protection Active

Each circuit board contains circuitry to help limit any permanent damage due to a mis-wire or short within the alarm pressure switch circuit. While this does not guarantee protection in all cases, if activated, this feature acts as a resettable fuse and will temporarily open the circuit to help prevent damage to the circuit board itself. If conditions warrant and this circuit has been activated, the panel will be unable to detect if the alarm pressure switch is closed. This condition will be indicated by a blinking Ready LED, steady Trouble LED, flashing alarm lamp and a corresponding message displayed on the LCD screen.

8.7 Watt-meter Operation

A faulty watt-meter indicates that the Protect Plus Panel has lost its ability to detect any of the following conditions: Brownout, Overvoltage, Run Dry, and Overpressure. This will be indicated with the amber Trouble LED and a corresponding error message displayed on the LCD screen. If this condition is present, contact E/One service personnel. While the pump can still operate in this mode, there is no ability to detect if any of these conditions are present; damage to the pump and/or system could occur.

8.8 Leak Detect Operation (E/One explosion proof pumps only)

An E/One explosion proof pump will communicate moisture intrusion from the motor and control compartments. This condition is indicated by a flashing Alarm Lamp, Trouble LED, and a Leak Detected LCD message. In addition, the Leak Detect field within the Initialize System mode will be set to a '1', and can only be cleared if the condition is removed. Leak Detection works by a series of pulses generated by the pump core onto the alarm return signal. These pulses are interpreted by the Protect Plus panel to distinguish a leak detect from other alarms from a wireless core that also use the alarm return signal for communication. Setting the Explosion Proof Ready setting within the Initialize System mode correctly ensures that the leak detect signal is interpreted correctly by the panel.

9 Diagnostics

The panel is equipped with a diagnostic tool to verify that all outputs are operational. These tests are available from the Diagnostic Mode and are divided into 3 categories. These categories can be selected using the 'Scroll' button.

9.1 LED Test

The first diagnostic test verifies operation of all LED's on the dead front overlay. The top four LED's will light in sequence and remain lit. The bottom 8 LED's will sequence one after the other and repeat. If any LED does not light during this test, consider having the dead front or panel serviced. Press 'Scroll' to move to the next test.

9.2 Button Test

The next diagnostic test verifies that all of the buttons on the dead front overlay work and can be detected by the panel. Pressing each button should result in that buttons name / function being displayed on the LCD screen. If any button does not register on the LCD display, consider having the dead front or panel serviced. For this test, pressing 'Scroll' will move to the next test, so it is suggested to verify this button last.

9.3 Relay Test

Warning! The system is taken off-line during the relay test and will be unable to respond to a high level alarm and may prevent the pump from running. Be sure to exit this feature and ensure the Ready LED is lit prior to leaving the station.

The last diagnostic test verifies the operation of all control relays. This includes the Manual Run relay, Alarm Lamp relay, Audible Alarm relay, Dry and Remote Sentry Contacts relay, and the Panel Contactor Coil relay. Use the 'Scroll' button to select each relay individually, then the ↑ 'A' and ↓ 'B' buttons can be used to alternate the state of the selected output. Each output can then be verified for proper operation individually. If any relay does not operate as expected the panel should be serviced. Press 'Scroll' to repeat the diagnostic test, or 'Mode' to exit.

10 Communication

The Protect Plus Panel can be read by an external device to provide system operating parameters for continuous system monitoring and predictive maintenance.

Except for the Data Push feature (refer to the [Data Push](#) option within the User Programmable Options section of this manual for more information on this feature), the panel is not able to initiate any communication and relies on an external device to read data. In addition, the circuit board itself does not provide any electrical isolation between external connections and the board circuitry itself. Special care is required when configuring your system to prevent transients and the like from causing damage to the communication interface. These interfaces are intended to communicate locally with a standalone transceiver device that provides the interface to the outside world.

The panel uses a Modbus communication protocol with the following parameters:

Modbus Type	RTU
Device Address	16
Base Register Offset	0
Baud Rate	9600
Data Bits	8 Bits
Parity	None
Stop Bits	1

10.1 Serial Interface

All panels can be configured with an RS-232 serial interface that can be used to read system registers. An optional Serial Interface Adaptor with a DB9 connector is provided on the dead front to allow connecting to a PC or other mobile device. Optional board configurations can provide an RS-485 interface.

A complete list of available parameters and their register locations can be found in the [System Parameters Memory Map](#) section of the Appendix at the back of this manual. Note that some registers are for internal purposes only and may not be useful to the end user. Please contact E/One for more information or to discuss your specific requirements.

10.2 Sentry Advisor Option

All panels can be updated to allow communication using the optional Sentry Advisor Remote Monitoring System. With the proper board configuration and operating software, the panel can be remotely monitored for various system operating parameters. Refer to E/One document NA0451P01 – ‘Sentry Advisor Remote Monitoring System Operation Manual’ for a complete description of the features of this system. Contact E/One Customer Service for more information on compatibility of this option with existing panels.

11 Wireless and Explosion Proof Pump Operation

Warning! If DIP switch position 4 is not properly set for the type of pump, flooding of the station can occur. Refer to the [DIP Switch](#) section of this manual for more information on setting the DIP Switches.

If the Protect Plus panel is installed with a wireless pump, which includes pumps configured for E/One Explosion Proof applications, some panel operations will change. A pump that is classified as wireless indicates that its level controls are not hardwired. Wireless pumps level information is communicated via a wireless interface from the pressure switches to a circuit board in the core. This is unique to wireless pumps. Because of this, all wireless pumps must have the DIP switches set to X-X-X-U (refer to the [DIP Switch](#) section of this manual). This setting overrides the panels redundant run feature that would normally accompany a High Level Alarm, as Redundant Run in a wireless pump is performed by the circuit board in the pump. This circuit board uses the Alarm Return signal to communicate not only a high level alarm, but also a loss of communication (between the pump and level sensors), as well as a leak detect signal (for E/One Explosion proof pumps) back to the panel. In addition, loss of pump power will also appear as an alarm from a wireless pump. Because an alarm signal from the pump may indicate more than just a high level, Redundant Run is disabled to prevent the pump from operating when it is not intended to.

E/One Explosion Proof pumps add a leak detection feature to indicate a potential breach of the explosion proof compartments. This too is a condition that is detected by the circuit board in the pump and is then communicated via the Alarm Return signal back to the panel as a series of pulses. The Protect Plus panel is able to decipher these pulses to determine a Leak Detect signal (refer to the [Leak Detect](#) section within the Pump Performance Mode for more information on this feature). In addition to the DIP Switch setting for Wireless, E/One Explosion Proof pumps must have the Expl. Proof option turned ON. This allows the panel to correctly identify the Leak Detect signal and react accordingly.

These features are unique to E/One wireless and Explosion Proof pumps only.

12 Trouble Shooting

The following chart is meant to address some common panel related issues. For more detailed information or pump specific troubleshooting, please refer to the appropriate Service Manual or contact E/One service personnel.

12.1 Troubleshooting Chart

Fault	Symptom	Possible Cause	Test
BROWNOUT	Voltage being measured by PCB is too low	Low incoming voltage	<ul style="list-style-type: none"> This testing may need to be done by qualified personal Check voltage at panel per manual
		Blown fuse or circuit breaker	<ul style="list-style-type: none"> Verify all fuses or breakers feeding the panel are on (closed)
		DIP switches incorrect	<ul style="list-style-type: none"> Verify DIP switches are correct and being read correctly by the PCB (Initialize System menu)
		Board out of Calibration	<ul style="list-style-type: none"> Verify incoming mains voltage and current match the LCD readout
OVERVOLTAGE	Voltage being measured by PCB is too high	High incoming voltage	<ul style="list-style-type: none"> This testing may need to be done by qualified personal Check voltage at panel per manual
		DIP switches incorrect	<ul style="list-style-type: none"> Verify DIP switches are correct and being read correctly by the PCB (Initialize System menu)
		Board out of Calibration	<ul style="list-style-type: none"> Verify incoming mains voltage and current match the LCD readout
RUN DRY	Pump runs continuously	Short in cable, manual run circuit shorted, Equalizer/on-off switch malfunction, short in pump, alarm switch malfunction	<ul style="list-style-type: none"> Refer to Service Manual and perform continuity test. If wireless or explosion proof refer to appropriate Service Manual. Refer to Service Manual and perform Megger insulation test
OVERPRESSURE	Excessive pump pressure	Discharge valve closed, check valve malfunction, line restriction, grinder restriction, bad motor	<ul style="list-style-type: none"> Remove pump from discharge and retest with no discharge (pump back into station) If problem is still present then refer to Service Manual for more testing
RUN LIMIT	Pump running longer then set time	Tank size too large, stator worn, high in-flow	<ul style="list-style-type: none"> Check amperage, wattage Change Excessive Run Time Limit
LEAK DETECT (explosion proof)	Moisture in control or motor compartment	Moisture has entered control or motor compartment	<ul style="list-style-type: none"> Perform air test on chambers before taking pump apart to determine entry point Refer to Service Manual for testing procedures
No pump via ON/OFF switch	Pump will not run on own but will run in manual run	ON/OFF switch not working, tank ventilation blocked trouble condition present.	<ul style="list-style-type: none"> Perform continuity test per Service Manual to determine if the switch is faulty Verify that the tank ventilation is clear
Panel will not power up	LCD Display and/or LED's do not power up	Overlay or display not plugged in or properly, no power to the board, faulty LCD, faulty LED's	<ul style="list-style-type: none"> Check to see that the display and overlay are plugged in properly, if this still does not fix try another display Check that wiring is correct per wiring schematic Check between neutral and both sides of the alarm breaker for 120v to determine if it is bad Check voltage at alarm feed, if no power at this location, replace board Perform self-tests via Diagnostic Menu
Contactors in panel will not engage	Pump will not run	No power to contactor coil, contactor bad	<ul style="list-style-type: none"> Check voltage at A1 to A2 coil on contractor Check continuity on contactor coil Perform self-tests via Diagnostic Menu
Contactors in panel engages but pump will not run	Pump will not run	No power coming out of contactor, loose wires, pump not working	<ul style="list-style-type: none"> Check for power across L1 & L2 (L1 & N) to see if power is going into the contactor, if no power then check incoming and breaker Then check T1 & T2 to see if it is going through the contactor, if not then replace the contactor Check voltage at the terminal block to see if power is there If all this is ok then refer to Service Manual for trouble shooting the pump

Fault	Symptom	Possible Cause	Test
Panel does not protect against fault conditions	No trouble faults, pump is not disabled for Brownout, Overvoltage, Run Dry, Overpressure, etc...	Protection mode turned off, panel contactor not functioning, panel contactor mis-wired, faulty PCB, DIP switches not set properly	<ul style="list-style-type: none"> • Verify Protect Mode is set to 'ON' (Initialize System Menu) • Verify board can command contactor to open using the Relay Diagnostic menu • Verify DIP switches are set properly, and that the panel is reading them correctly (Initialize System Menu)
Redundant run is not working	High water alarm does not run pump	Panel is turned off, mis-wired panel, faulty PCB	<ul style="list-style-type: none"> • Verify all wires are per wiring instruction • Perform self test via Diagnostic Menu
Manual run not working	Manual run does not make pump run	Panel mis-wired, faulty manual run button, faulty PCB, trouble condition present	<ul style="list-style-type: none"> • Check wiring of panel, all wires need to be per wiring instruction • Verify Manual Run is possible via Diagnostic menu
Watt-meter Failure	LCD displays WM COMM FAILURE	Brown wires from PCB are loose or mis-wired, faulty PCB, pump breaker off or tripped (open)	<ul style="list-style-type: none"> • Verify wires are connected as per decal inside panel cover • Replace PCB if necessary

13 Appendix

13.1 System Parameters Memory Map

Note: Some registers are for internal use only and may not contain information that is useful to the end user.

Register Name	Offset	Size*	Contents	Cat.
RegisterTableVersion	0	1	Reserved	Rev
SoftwareVersion	1	1	Code Revision	
NOENTRY	2	1	Reserved	
WattmeterVoltageAverage	3	1	Volts	Operating Parameters
WattmeterCurrentAverage	4	1	Amps	
WattmeterWattage	5	1	Watts	
CurrentFlags	6	3	Status Flags (See Below)	
Cycles	9	2	Regular Pump Run Cycles	
ManCycles	11	2	Manual Run Cycles	
RunTime	13	2	Regular Run Time	
ManRunTime	15	2	Manual Run Time	
AvgTime	17	2	Avg. Pump Run Time	
ManAvgTime	19	2	Avg. Man Run Time	
LastRunTime	21	2	Last Pump Run Time	
VoltsSum	23	2	Accumulated Volts - Internal use only	
AmpsSum	25	2	Accumulated Amps - Internal use only	
WattsSum	27	2	Accumulated Watts - Internal use only	
MinRunTime	29	2	Minimum Pump Runtime (since last reset)	
MaxRunTime	31	2	Maximum Pump Runtime (since last reset)	
VoltsMax	33	1	Maximum Pump Voltage (since last reset)	
AmpsMax	34	1	Maximum Pump Amperage (since last reset)	
WattsMax	35	1	Maximum Pump Wattage (since last reset)	
VoltsMin	36	1	Minimum Pump Voltage (since last reset)	
AmpsMin	37	1	Minimum Pump Amperage (since last reset)	
WattsMin	38	1	Minimum Pump Wattage (since last reset)	

Register Name	Offset	Size*	Contents	Cat.
RelayMask	39	1	Relay Status	Misc.
RunLimit	40	1	Current Run Limit Setting	User Settings
AlarmDelay	41	1	Current Alarm Delay Setting	
PowerDelay	42	1	Current Power Delay Setting	
Flags	43	1	Current Options Setting (see below)	
LowWattLimit	44	1	Current Run Dry Setting	
HiWattLimit	45	1	Current Overpressure Setting	
WGAIN	46	1	Wattage Calibration Value	Cal
I_LSB	47	1	Current Calibration Value	
V_LSB	48	1	Voltage Calibration Value	
LowVoltOff	49	1	Brownout React Limit	System Status / Settings
LowVoltOn	50	1	Brownout Recover Limit	
HiVoltOff	51	1	Overvoltage React Limit	
HiVoltOn	52	1	Overvoltage Recover Limit	
DipSwitchSetting	53	1	Current DIP Switch Setting	
s_ManualRun	54	1	Manual Run Status / Command	
TroubleMsgID	55	1	ID of Current Trouble Msg	
PumpLEDMask	56	1	Membrane Pump LED's Status	
UserLEDMask	57	1	Membrane User LED's Status	

* a register is a single memory location that is 16 bits in size

Current Flags Register 6 - BITS		
BIT Name	BIT**	Contents
ManualRun	0	Manual Run is Active
Brownout	1	Brownout Protection is Active
Overvoltage	2	Overvoltage Protection is Active
PumpRunning	3	Pump is Currently Running
HighLevelAlarm	4	High Level is Active
HighLevelAlarmPending	5	High Level Alarm Delay Active
RunDry	6	Run Dry Alarm is Active
OverPressure	7	Overpressure Alarm is Active
AlarmLatchBuzzerActive	0	Buzzer Corresponding to a Latched Alarm is Active
BuzzerActive	1	Buzzer is Active
LeakDetect	2	Leak Detectd
RD_OP_LatchActive	3	Run Dry or Overpressure Latch is Active
AlarmLatchActive	4	Alarm Latch is Active
PowerDelayActive	5	Power Delay is Active
OverPressureLockoutFlag	6	Overpressure 20-Minute Lockout is Active
RunDryLockoutFlag	7	Run Dry 20-Minute Lockout is Active

Current Flags Register 7 - BITS		
BIT Name	BIT**	Contents
WattmeterHealthy	0	Wattmeter is Functioning
AlarmProtectActive	1	Alarm Circuit Fault Detected
RunLimitFlag	2	Pump Running has Reached Run Limit
PowerUp	3	Board is in Power Up routine / Power Up delay
Wireless	4	Wireless Pump Option is Set
WirelessAlarm	5	Wireless Pump Fault (HLA, PWR LOSS, COMM)
DipSwitchFault	6	Non-recognized DIP switch Setting
ProtectPlusMembrane	7	Protect Plus vs. Protect Membrane
ClockError	0	Processor running on internal clock
LCDBusy	1	
WattmeterCalibrate	2	Wattmeter is Calibrating
ExplosionProofEnabled	3	Explosion Proof Pump Option is Set
NOT ASSIGNED	4	
NOT ASSIGNED	5	
NOT ASSIGNED	6	
NOT ASSIGNED	7	

Current Flags Register 8 - BITS		
BIT Name	BIT**	Contents
NOT ASSIGNED	0	
NOT ASSIGNED	1	
NOT ASSIGNED	2	
NOT ASSIGNED	3	
NOT ASSIGNED	4	
NOT ASSIGNED	5	
NOT ASSIGNED	6	
NOT ASSIGNED	7	
NOT ASSIGNED	0	
NOT ASSIGNED	1	
NOT ASSIGNED	2	
NOT ASSIGNED	3	
NOT ASSIGNED	4	
NOT ASSIGNED	5	
NOT ASSIGNED	6	
NOT ASSIGNED	7	

User Options Flags Register 42 - BITS - Refer to Manual		
BIT Name	BIT**	Contents (setting if '1')
BuzzerTimer	0	Optional Buzzer Timer is Set
AlarmLatch	1	Optional Alarm Latch is Set
TroubleMode	2	Trouble set to LED & LAMP
ProtectDisable	3	Pump Protection is Disabled
ExplosionProof	4	Explosion Proof Pump is Set
OverPressureCVC	5	Optional Overpressure Re-try Timing is Set
RunLimit24Hour	6	Optional 24-Hour Run Limit is Set
DataPushEnable	7	Sentry Advisor Pump Run Data Push is Set
NOT ASSIGNED	0	
NOT ASSIGNED	1	
NOT ASSIGNED	2	
NOT ASSIGNED	3	
NOT ASSIGNED	4	
NOT ASSIGNED	5	
NOT ASSIGNED	6	
NOT ASSIGNED	7	

** each 'Flag' register is broken up into two byte (8-bit) locations as indicated
 Grayed values are reserved or for internal use only.

13.2 LCD Messages

The following messages may be displayed on the LCD to indicate various system conditions.

- ALARM PROTECT – indicates a short or mis-wire in the alarm circuit causing the circuit board to open the circuit to prevent permanent damage to the printed circuit board. The system is unable to detect an alarm for a pump when this message is displayed
- HIGH LEVEL – indicates a High Level is still present even after enabling both pumps
- DELAYED ALARM – indicates a High Level is present but both pumps are enabled and pumping together
- FAILED WM COM – indicates a circuit board is unable to read a pumps voltage, amperage, or wattage
- OSC FAIL – indicates there is a problem with the microprocessor timing and that certain external communication may be unavailable
- DIP SW ERROR – indicates that the DIP switches are set to an invalid setting, or that there is a hardware problem with the switches themselves
- BROWNOUT – indicates the AC mains voltage feeding a pump is below the minimum limit
- OVER VOLTAGE – indicates the AC mains voltage feeding a pump is above the maximum limit
- RUN DRY – indicates a pumps wattage draw is below the minimum limit
- OVERPRESSURE – indicates a pumps wattage draw is above the maximum limit
- RUN LIMIT – indicates a pump runtime has exceeded the limit set under the Run Limit setting
- LEAK DETECTED – This message does not apply to hardwired pumps. Contact E/One for more information.
- WIRELESS ALARM – This message does not apply to hardwired pumps. Contact E/One for more information.
- LATCHED ALARM – indicates that a High Level Alarm has occurred and is latched, but is not currently present
- LATCHED RD/OP – indicates that a Run Dry or Overpressure has occurred and is latched, but is not currently present

13.3 Wiring Diagrams

13.3.1 240V, 2-leg basic panel wiring (for US installations)

OLD / NEW WIRE COLOR MAP

PIN	FUNCTION	2000S/WIRELESS	EXTREME
1	MANUAL RUN	RED	BROWN
2	L1	BLACK	RED
3	L2	WHITE	BLACK
4	GND	GREEN	GRN/YEL
5	ALARM FEED	ORANGE	YELLOW
6	ALARM RETURN	BLUE	BLUE

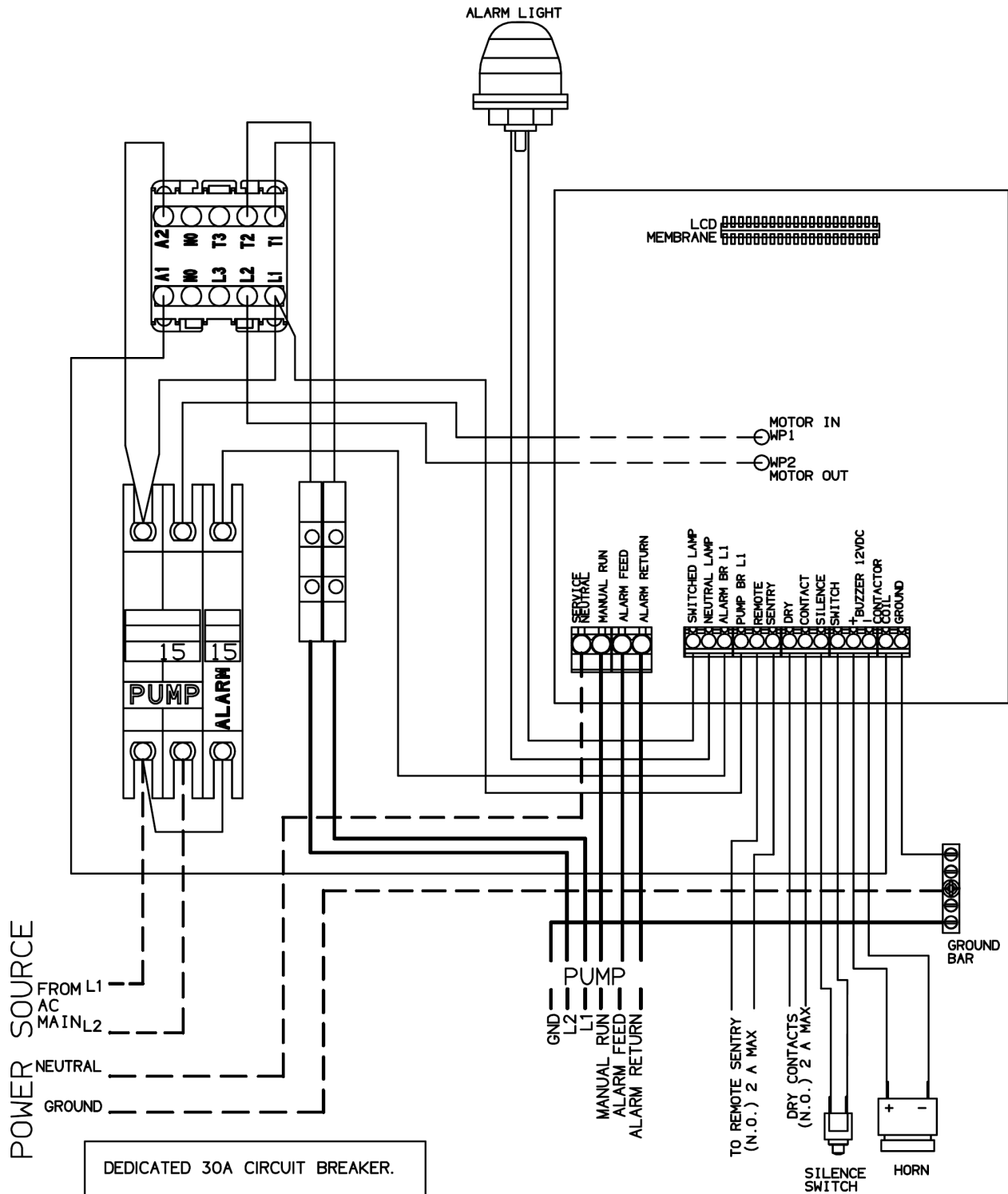

13.3.2 240V, 2-leg optional panel wiring (for US installations)

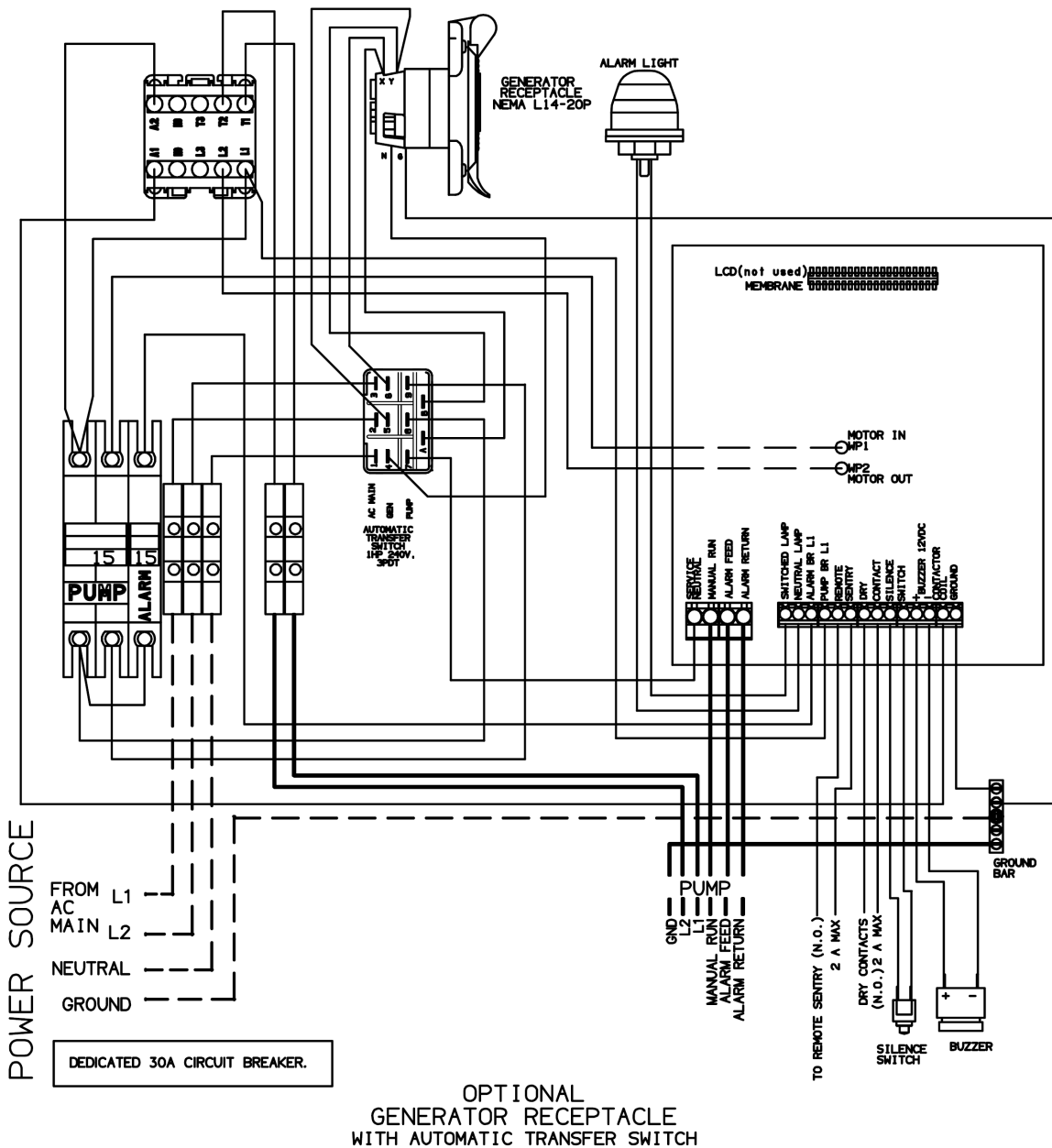
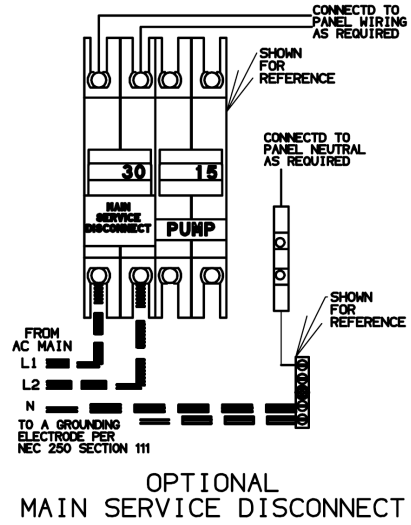
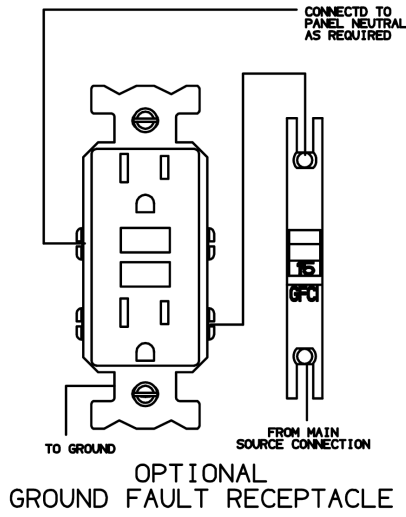

13.3.3 240V, 1-leg basic panel wiring (for non-US installations)

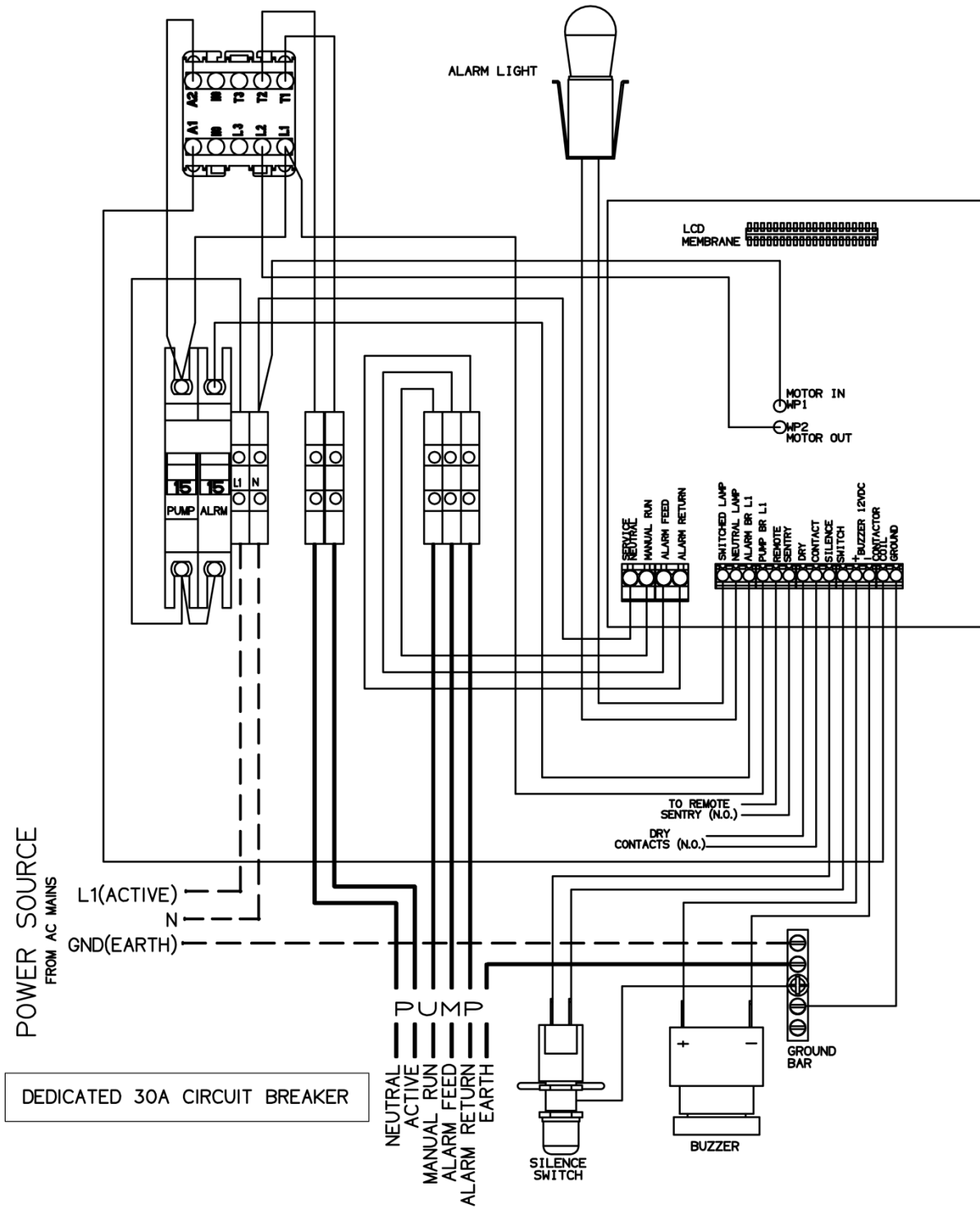

OLD / NEW WIRE COLOR MAP

PIN	FUNCTION	2000S	EXTREME
1	MANUAL RUN	RED	BROWN
2	L1 (ACTIVE)	BLACK	RED
3	NEUTRAL	WHITE	BLACK
4	GND (EARTH)	GREEN	GRN/YEL
5	ALARM FEED	ORANGE	YELLOW
6	ALARM RETURN	BLUE	BLUE

13.3.4 240V, 1-leg with optional generator receptacle, manual transfer switch (for non-US installations)

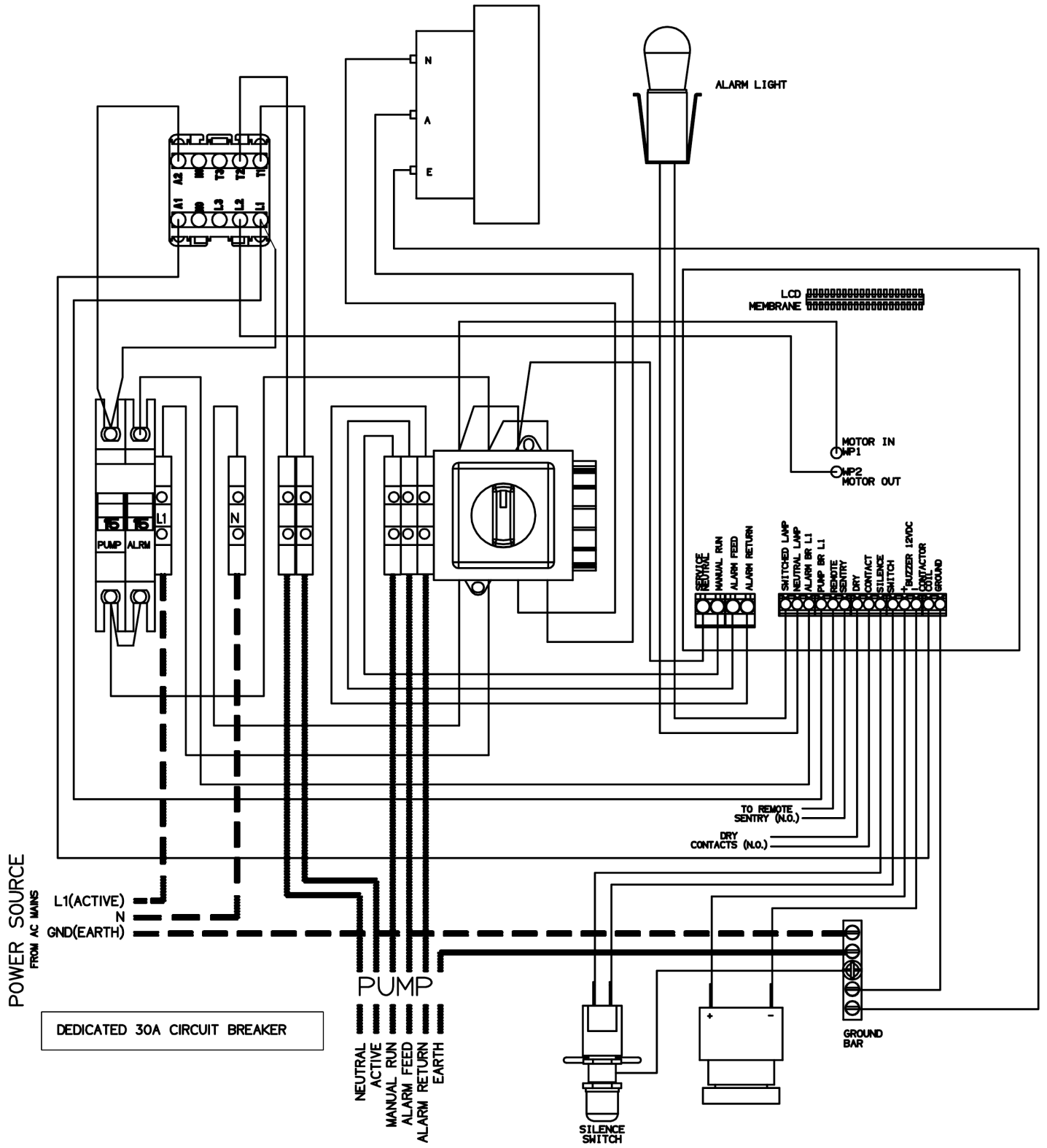



A Precision Castparts Company

Environment One Corporation
2773 Balltown Road
Niskayuna, New York 12309-1090

Voice: (01) 518.346.6161
Fax: 518.346.6188

www.eone.com