

WX

Explosionproof Grinder Pump

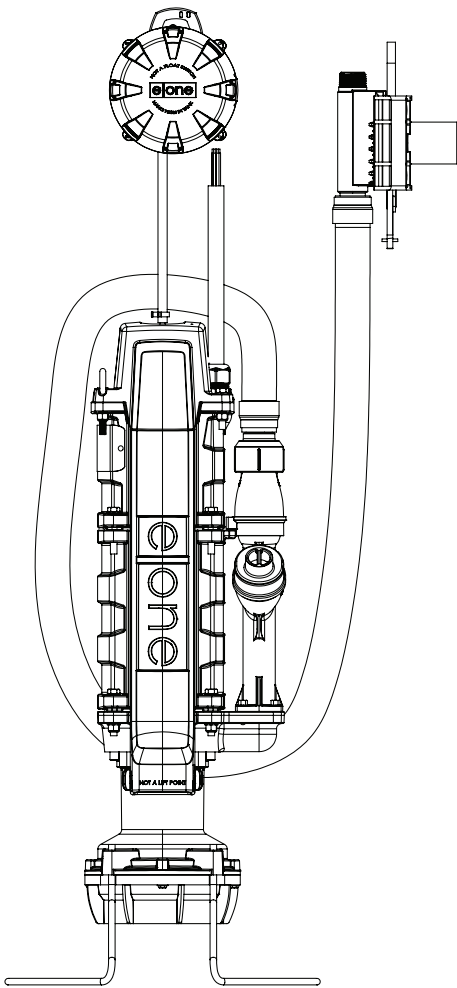

General Features

The E/One model WX explosionproof grinder pump is engineered to meet the stringent Factory Mutual™ explosionproof equipment standards for use in locations classified as Class I, Division 1, Group D (approval standards 3600, 3610, and 3615).

The WX pump comes complete with a self-contained level control system, eliminating troublesome float switches. The pump uses radio frequency identification (RFID) technology to communicate between the level controls and the motor controls.

The grinder pump is activated automatically and runs infrequently for very short periods. The internal check valve assembly, located in the grinder pump, is custom-designed for non-clog, trouble-free operation.

- Designed not to jam and for minimum wear to the grinding mechanism
- Universal design allows for easy installation into open wetwell tanks
- Available with a range of discharge hose lengths to accommodate a wide range of tank depths

Operational Information

Motor

1 hp, 1,725 rpm, high torque, capacitor start, thermally protected, 240V, 60 Hz, 1 phase

Discharge Connections

Pump discharge terminates in 1.25-inch female solvent weld fitting; threaded adapter is supplied and discharge can easily be adapted to 1.25-inch NPT.

Discharge

15 gpm at 0 psig (0.95 lps at 0 m)

11 gpm at 40 psig (0.69 lps at 28 m)

7.8 gpm at 80 psig (0.49 lps at 56 m)

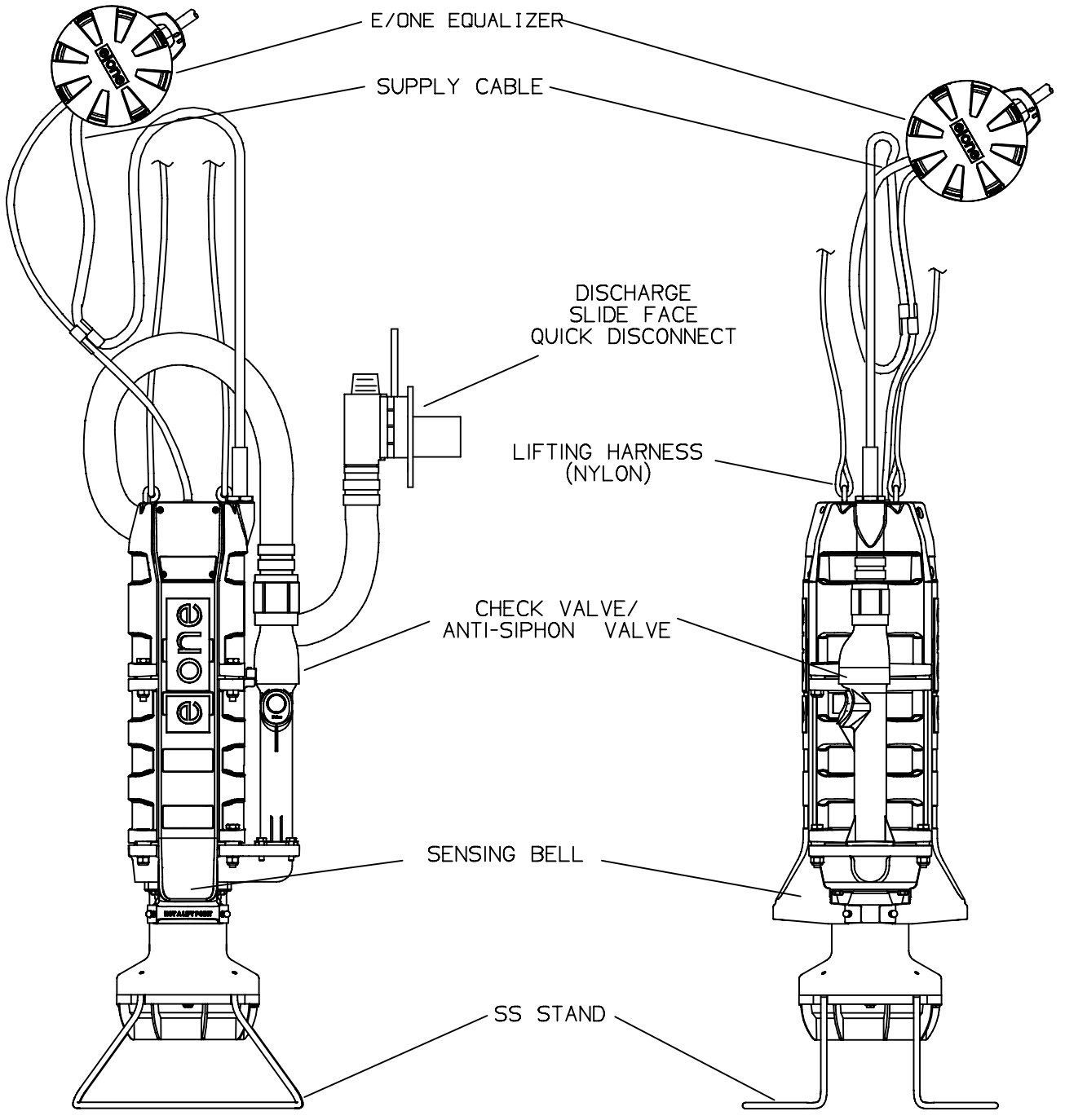

EXPLOSION PROOF GRINDER PUMP

NOTE:

THE PUMP ASSEMBLIES ARE LISTED BY ETL TO FACTORY MUTUAL (FM) STANDARDS FOR CLASS 1, DIVISION 1, GROUP D, THE LEVEL CONTROL SYSTEM, INTEGRAL TO THE PUMP, IS INTRINSICALLY SAFE

ALSO AVAILABLE APPROVED BY CSA FOR CLASS 1, DIVISION 1, GROUP D

AD	DB	12/09/10	A	
DR BY	CHK'D	DATE	ISSUE	SCALE



EXPLOSION PROOF GRINDER PUMPS

LM000373

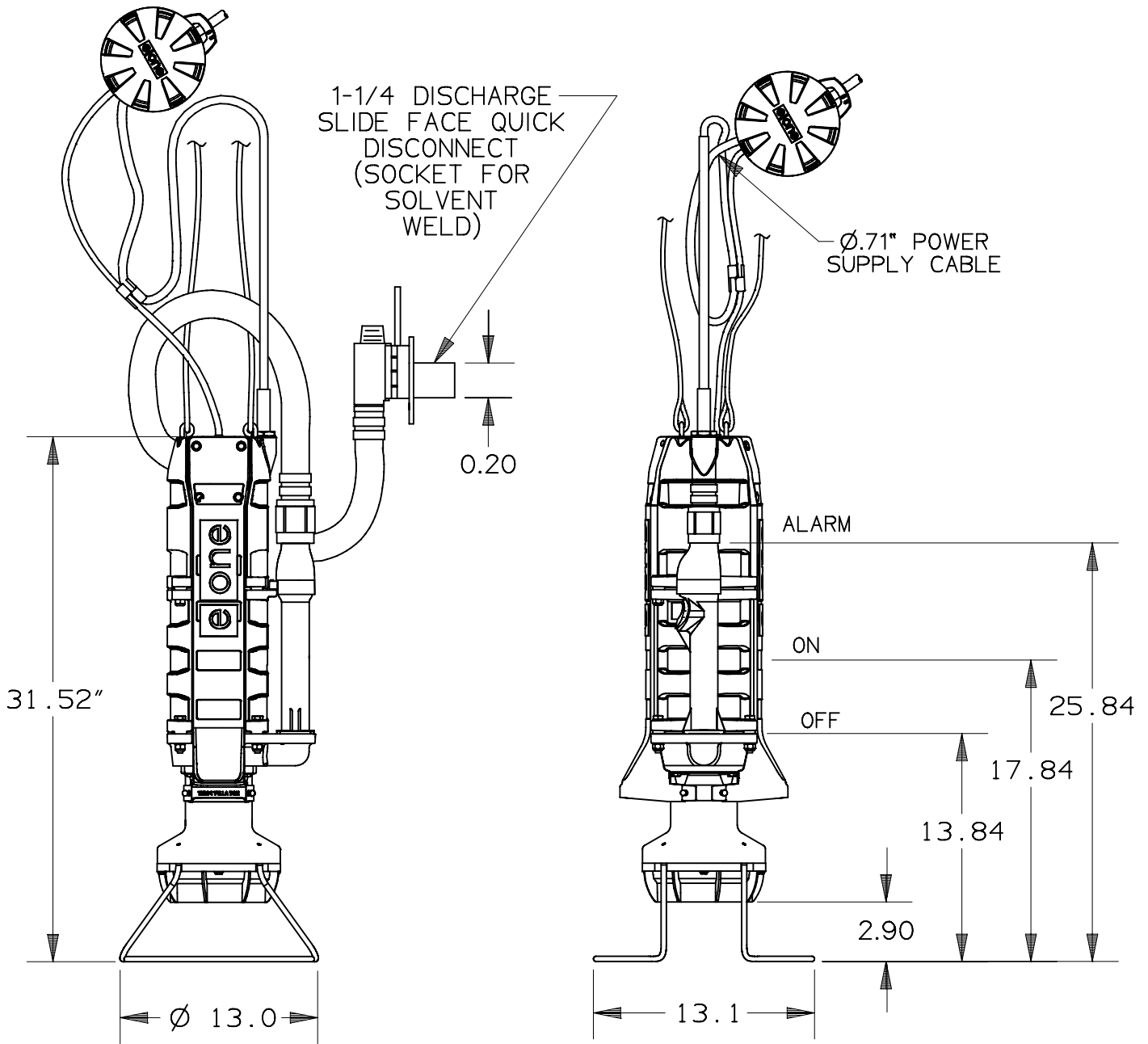

EXPLOSION PROOF GRINDER PUMP

NOTE:

THE PUMP ASSEMBLIES ARE LISTED BY ETL TO FACTORY MUTUAL (FM) STANDARDS FOR CLASS 1, DIVISION 1, GROUP D, THE LEVEL CONTROL SYSTEM, INTEGRAL TO THE PUMP, IN INTRINSICALLY SAFE

ALSO AVAILABLE APPROVED BY CSA FOR CLASS 1, DIVISION 1, GROUP D

SGS	DS	10/03/11	B	
DR BY	CHK'D	DATE	ISSUE	SCALE



DIMENSION SHEET, EXPLOSION PROOF

LM000374

WX SERIES, EXPLOSION PROOF PUMP IN A W SERIES SIMPLEX BASIN

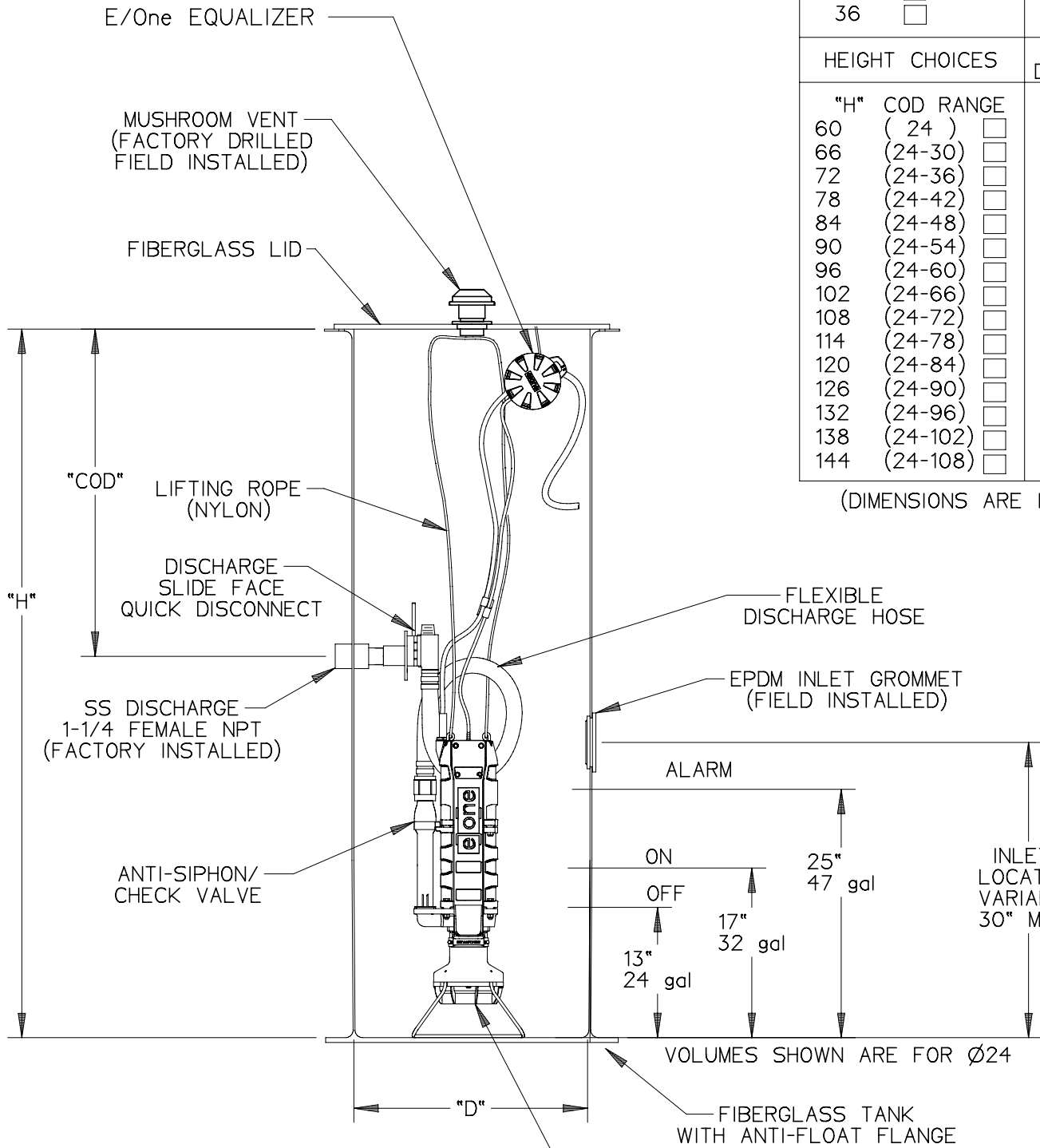

DIAMETER CHOICES		W SERIES SIMPLEX STATIONS
"D"		
24	<input type="checkbox"/>	
30	<input type="checkbox"/>	
36	<input type="checkbox"/>	
HEIGHT CHOICES		COVER OVER DISCH CHOICES
"H"	COD RANGE	
60	(24) <input type="checkbox"/>	"COD" 24 <input type="checkbox"/>
66	(24-30) <input type="checkbox"/>	30 <input type="checkbox"/>
72	(24-36) <input type="checkbox"/>	36 <input type="checkbox"/>
78	(24-42) <input type="checkbox"/>	42 <input type="checkbox"/>
84	(24-48) <input type="checkbox"/>	48 <input type="checkbox"/>
90	(24-54) <input type="checkbox"/>	54 <input type="checkbox"/>
96	(24-60) <input type="checkbox"/>	60 <input type="checkbox"/>
102	(24-66) <input type="checkbox"/>	66 <input type="checkbox"/>
108	(24-72) <input type="checkbox"/>	72 <input type="checkbox"/>
114	(24-78) <input type="checkbox"/>	78 <input type="checkbox"/>
120	(24-84) <input type="checkbox"/>	84 <input type="checkbox"/>
126	(24-90) <input type="checkbox"/>	90 <input type="checkbox"/>
132	(24-96) <input type="checkbox"/>	96 <input type="checkbox"/>
138	(24-102) <input type="checkbox"/>	102 <input type="checkbox"/>
144	(24-108) <input type="checkbox"/>	108 <input type="checkbox"/>

(DIMENSIONS ARE IN INCHES)

SEMI-POSITIVE DISPLACEMENT TYPE PUMP
DIRECTLY DRIVEN BY 1 HP MOTOR

INLET CHOICES	
4" DWV PIPE (4.50 OD)	<input type="checkbox"/>
4" DR35 PIPE (4.22 OD)	<input type="checkbox"/>
6" DWV PIPE (6.63 OD)	<input type="checkbox"/>
6" DR35 PIPE (6.28 OD)	<input type="checkbox"/>

NOTE:

THE PUMP ASSEMBLY IS LISTED BY ETL TO FACTORY MUTUAL (FM) STANDARDS FOR CLASS I, DIVISION I, GROUP D. THE LEVEL CONTROL SYSTEM, INTEGRAL TO THE PUMP, IS INTRINSICALLY SAFE (THE STATION IS NOT PART OF THE LISTING)
-ALSO AVAILABLE APPROVED BY CSA FOR CLASS 1, DIVISION 1, GROUP D

SGS		12/3/10	A	1/16
DR BY	CHK'D	DATE	ISSUE	SCALE



WX SERIES PUMP IN A SIMPLEX
W SERIES STATION

NA0133P01

WX SERIES EXPLOSION PROOF PUMP IN A W SERIES DUPLEX BASIN

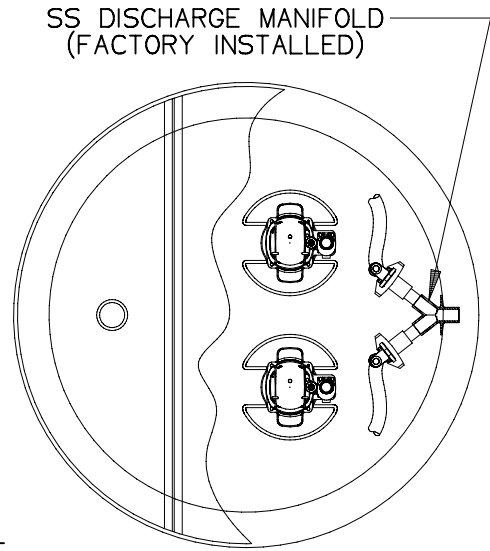

DIAMETER CHOICES		W SERIES DUPLEX STATIONS	
"D"			
36	<input type="checkbox"/>		
42	<input type="checkbox"/>		
48	<input type="checkbox"/>		
60	<input type="checkbox"/>		
HEIGHT CHOICES		COVER OVER DISCH CHOICES	
"H"	COD RANGE	"COD"	
60	(24)	24	<input type="checkbox"/>
66	(24-30)	30	<input type="checkbox"/>
72	(24-36)	36	<input type="checkbox"/>
78	(24-42)	42	<input type="checkbox"/>
84	(24-48)	48	<input type="checkbox"/>
90	(24-54)	54	<input type="checkbox"/>
96	(24-60)	60	<input type="checkbox"/>
102	(24-66)	66	<input type="checkbox"/>
108	(24-72)	72	<input type="checkbox"/>
114	(24-78)	78	<input type="checkbox"/>
120	(24-84)	84	<input type="checkbox"/>
126	(24-90)	90	<input type="checkbox"/>
132	(24-96)	96	<input type="checkbox"/>
138	(24-102)	102	<input type="checkbox"/>
144	(24-108)	108	<input type="checkbox"/>

(DIMENSIONS ARE IN INCHES)

ALUMINUM 1/3 - 2/3 SPLIT LOCKABLE LID

MUSHROOM VENT (FACTORY DRILLED FIELD INSTALLED)

E/ONE EQUALIZER

LIFTING ROPE (NYLON)

DISCHARGE SLIDE FACE QUICK DISCONNECT "COD"

SS DISCHARGE HUB 1 1/4" FEMALE NPT (FACTORY INSTALLED) "H"

EPDM INLET GROMMET (FIELD INSTALLED)

ANTI-SIPHON CHACK VALVE

INLET LOCATION VARIABLE 30" MIN

FLEXIBLE DISCHARGE HOSE

ALARM ON OFF

13" 102 gal
17" 133 gal
25" 196 gal

FIBERGLASS TANK WITH ANTI-FLOAT FLANGE

"D"

VOLUMES SHOWN ARE FOR Ø48"

SEMI-POSITIVE DISPLACEMENT TYPE PUMP DIRECTLY DRIVEN BY 1 HP MOTOR

INLET CHOICES	
4" DWV PIPE (4.50 OD)	<input type="checkbox"/>
4" DR35 PIPE (4.22 OD)	<input type="checkbox"/>
6" DWV PIPE (6.63 OD)	<input type="checkbox"/>
6" DR35 PIPE (6.28 OD)	<input type="checkbox"/>

NOTE:

THE PUMP ASSEMBLIES ARE LISTED BY ETL TO FACTORY MUTUAL (FM) STANDARDS FOR CLASS I, DIVISION I, GROUP D, THE LEVEL CONTROL SYSTEM, INTEGRAL TO THE PUMP, IS INTRINSICALLY SAFE (THE STATION IS NOT PART OF THE LISTING)
- ALSO AVAILABLE APPROVED BY CSA FOR CLASS 1, DIVISION 1, GROUP D

SGS		12/3/10	A	1/32
DR BY	CHK'D	DATE	ISSUE	SCALE



WX SERIES PUMP IN A DUPLEX W SERIES STATION

NA0134P01

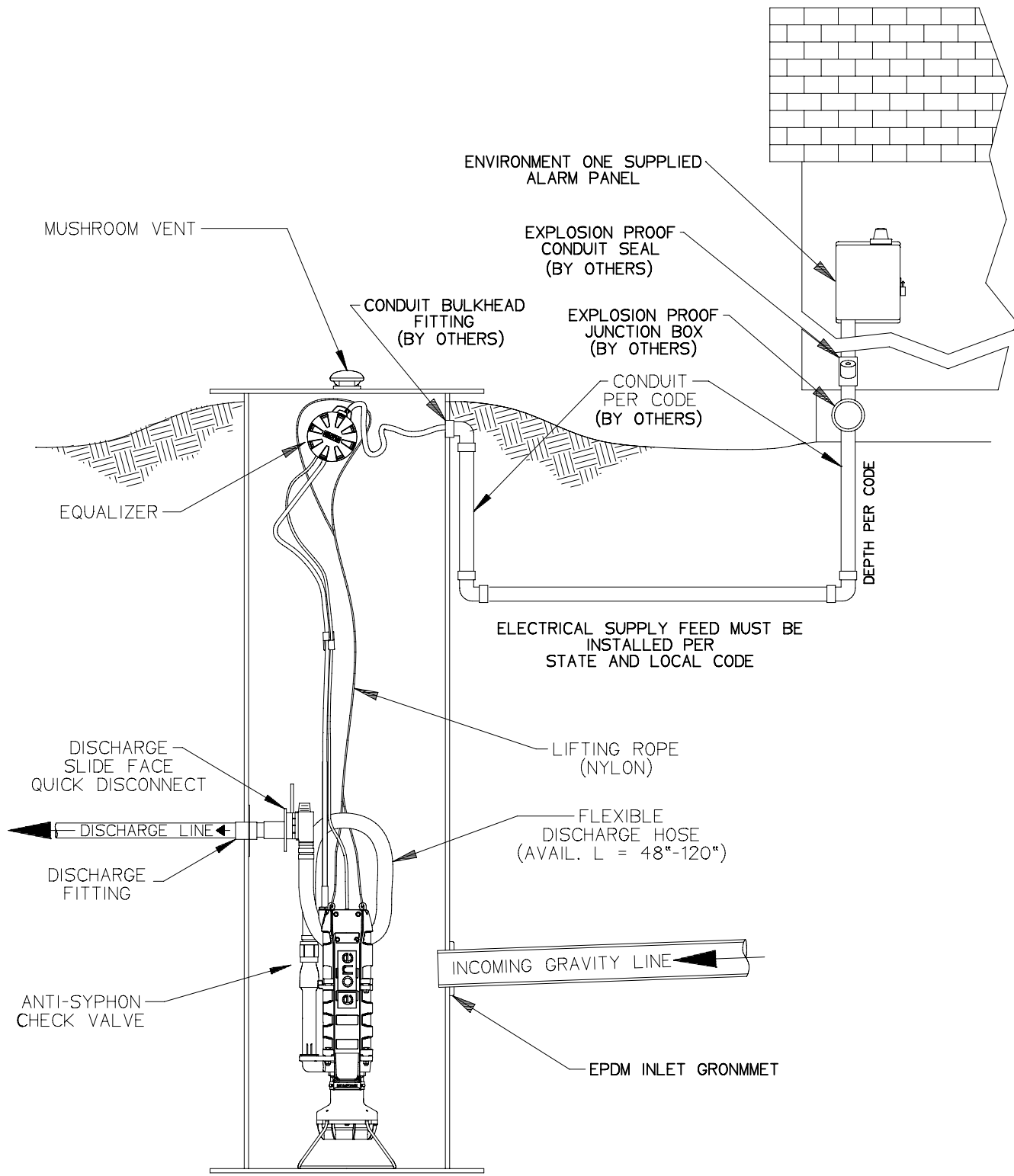

ELECTRICAL SUPPLY FEED MUST BE INSTALLED PER STATE AND LOCAL CODE

NOTE:

THE PUMP ASSEMBLY IS LISTED BY ETL TO FACTORY MUTUAL (FM) STANDARDS FOR CLASS I, DIVISION I, GROUP D, THE LEVEL CONTROL SYSTEM, INTEGRAL TO THE PUMP, IS INTRINSICALLY SAFE (THE STATION IS NOT PART OF THE LISTING)
 -ALSO AVAILABLE APPROVED BY CSA FOR CLASS 1, DIVISION 1, GROUP D

SGS	CAH	12/3/10	A	1/16
DR BY	CHK'D	DATE	ISSUE	SCALE



WX SERIES, TYPICAL INSTALLATION

NA0132P01